

# Rosemount 148 Temperature Transmitter

- Provides an installation-ready solution for temperature monitoring applications using Complete Point Solutions (CPS)
- Increases measurement accuracy and reliability over sensors wired direct
- Accepts 2-, 3-, and 4-wire RTD, thermocouple, and ohm sensor inputs
- Reduces overall installed costs compared to wiring sensors direct
- Configurable using the Rosemount PC Programmer interface device



## Content

Transmitter Specifications . . . . .	page 3
Product Certifications . . . . .	page 6
Dimensional Drawings . . . . .	page 8
Ordering Information . . . . .	page 9

## The Rosemount 148 Temperature Transmitter

The Rosemount 148 is a low cost temperature transmitter used with multiple sensor type inputs in monitoring applications. The Rosemount 148 saves money in cabling and installation costs over wiring directly and delivers superior measurement accuracy and reliability.

### INSTALLATION READY SOLUTIONS

The Rosemount 148 is part of the Complete Point Solutions (CPS) program. CPS guarantees that the transmitter, housing, sensor, extension, and thermowell can be shipped from the factory as an installation-ready assembly.

### INCREASED PERFORMANCE

The Rosemount 148 offers better measurement accuracy and improved reliability over wiring a temperature sensor directly back to the DCS.

### FLEXIBILITY

The Rosemount 148 is compatible with 2-, 3-, and 4-wire nickel and platinum RTDs, a variety of thermocouple sensors, and ohm inputs.

### LOW INSTALLED COST

The Rosemount 148 reduces overall installation costs when compared to wiring sensors direct. In addition, the 148 can eliminate the use of expensive extension wires and multiplexers.

### PROGRAMMABLE

The Rosemount 148 PC Programmer interface consists of a programmer, cables, and configuration software. The configuration software, when used in conjunction with the interface, provides the tools necessary to select the sensor type, sensor range, and sensor error action in addition to many other options.

## ROSEMOUNT TEMPERATURE SOLUTIONS

### Rosemount 3144P

Field mount style HART<sup>®</sup> or FOUNDATION<sup>™</sup> fieldbus protocol. Dual sensor input with advanced diagnostics.

### Rosemount 644 Smart Temperature Transmitter

Head mount styles available with HART<sup>®</sup> or FOUNDATION<sup>™</sup> fieldbus protocol. Rail mount style available for HART protocol.

### Rosemount 848T Eight Input Temperature Transmitter

Eight input transmitter available with FOUNDATION<sup>™</sup> fieldbus protocol.

### Rosemount 3420 Fieldbus Interface Module

Provides an interface between FOUNDATION<sup>™</sup> fieldbus instruments and systems without fieldbus capability using standard interface protocols.

### Rosemount 248 Temperature Transmitter

Head mount (DIN B) and Rail mount style with HART<sup>®</sup> protocol and complete temperature assembly.

### Rosemount sensors, thermowells, and extensions

Rosemount has a broad offering of RTD and thermocouples that are designed to meet plant requirements.

# Transmitter Specifications

## FUNCTIONAL SPECIFICATIONS

### Inputs

User-selectable; sensor terminals rates to 42.4 V dc. See "Transmitter Accuracy and Ambient Temperature Effects" on page 4 for sensor options.

### Output

2-wire 4–20 mA, linear with temperature or input.

### Isolation

Input/Output isolation tested to 500V ac rms (707 V dc) at 50/60 Hz.

### Supply Voltage DC

Standard: 12 to 35 V  
 Intrinsic Safety: 12 to 28 V

### Minimum Voltage Across Terminals

12 V dc

### Humidity Limits

0 - 95% relative humidity, non-condensing

### NAMUR Recommendations

The 148 meets the following NAMUR recommendations:

- NE 21 - Electromagnetic compatibility (EMC) for Process and Laboratory Apparatus
- NE 43 - Standard of the signal level breakdown information of digital transmitters

### Transient Protection

The optional rosemount 470 Transient Protector prevents damage from transients induced by lightning, welding, heavy electrical equipment, or switch gears. Refer to the 470 Product Data Sheet (document number 00813-0100-4191) for more information.

### Temperature Limits

Operating Limit

- -40 to 185 °F (-40 to 85 °C)

Storage Limit

- -58 to 248 °F (-50 - 120 °C)

### Turn-on Time

Performance within specifications is less than 5.0 seconds after power is applied to the transmitter, when damping value is set to zero seconds.

### Update Rate

Less than 0.5 seconds

### Damping

32 seconds maximum, 5 seconds default.

### Recommended Minimum Measuring Span

18 °F (10 °C)

### Software Detected Failure Mode

The values at which the transmitter drives its output in failure mode depends on device configuration. The device can be configured to meet NAMUR-compliant (NAMUR recommendation NE 43) operation. The values for standard and NAMUR-compliant operation are as follows:

TABLE 1. Operation Parameters

	Standard <sup>(1)</sup>	NAMUR NE43-Compliant <sup>(1)</sup>
Linear Output:	$3.9 \leq I \leq 20.5$	$3.8 \leq I \leq 20.5$
Fail High:	$21 \leq I \leq 23$ (default)	$21 \leq I \leq 23$ (default)
Fail Low:	$I \leq 3.75$	$I \leq 3.6$

(1) Measured in milliamperes

Certain hardware failures, such as microprocessor failures, will always drive the output to greater than 23 mA.

## PERFORMANCE SPECIFICATIONS

### EMC (ElectroMagnetic Compatibility) NAMUE NE21 Standard

The 148 meets the requirements for NAMUR NE21 Rating

Susceptibility	Parameter	Influence
ESD	<ul style="list-style-type: none"> <li>• 6 kV contact discharge</li> <li>• 8 kV air discharge</li> </ul>	None
Radiated	• 80 – 1000 MHz at 10 V/m AM	None
Burst	• 1 kV for I.O.	None
Surge	<ul style="list-style-type: none"> <li>• 0.5 kV line–line</li> <li>• 1 kV line–ground (I.O. tool)</li> </ul>	None
Conducted	• 150 kHz to 80 MHz at 10 V	None

### CE Mark

The 148 meets all of the requirements listed under IEC 61326: Amendment 1, 2006.

### Power Supply Effect

Less than ±0.0055 of span per volt.

### Vibration Effect

The 148 is tested to the following specifications with no effect on performance:

Frequency	Vibration
10 to 60 Hz	0.21 mm displacement
60 to 2000 Hz	3 g peak acceleration

## Stability

For RTD and thermocouple inputs, the transmitter will have a stability of  $\pm 0.15\%$  of reading or  $0.15\text{ }^\circ\text{C}$  (whichever is greater) for twelve months.

## Sensor Connections

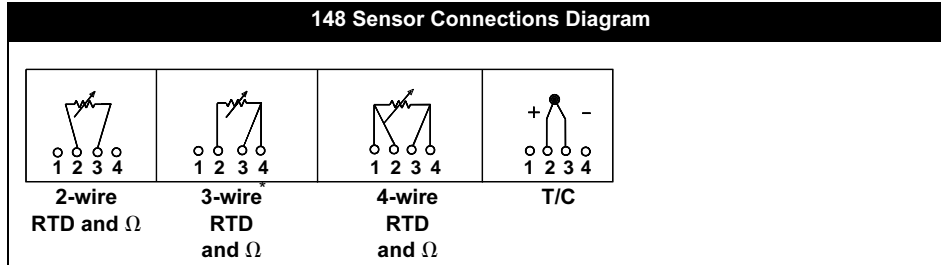

\* Rosemount Inc. provides 4-wire sensors for all single element RTDs. You can use these RTDs in 3-wire configurations by leaving the unneeded leads disconnected and insulated with electrical tape.

## Transmitter Accuracy and Ambient Temperature Effects

### NOTE

The accuracy and ambient temperature effect is the greater of the fixed and percent of span values (see example below).

TABLE 2. 148 Transmitter Input Options, Accuracy, and Ambient Temperature Effects

Sensor	Transmitter Input Ranges <sup>(1)</sup>		Accuracy		Temperature Effects per 1.0 °C (1.8 °F) Change in Ambient Temperature <sup>(2)()</sup>	
	°C	°F	Fixed	% of Span	Fixed	% of Span
2-, 3-, 4-wire RTDs						
Pt 100 <sup>(3)</sup> ( $\alpha = 0.00385$ )	-200 to 850	-328 to 1562	0.3 °C (0.54 °F)	$\pm 0.15$	0.009 °C (0.016 °F)	$\pm 0.006$
Pt 100 <sup>(4)</sup> ( $\alpha = 0.003916$ )	-200 to 645	-328 to 1193	0.3 °C (0.54 °F)	$\pm 0.15$	0.009 °C (0.016 °F)	$\pm 0.006$
Ni 120 <sup>(5)</sup>	-70 to 300	-94 to 572	0.2 °C (0.36 °F)	$\pm 0.15$	0.006 °C (0.011 °F)	$\pm 0.006$
Cu 10 <sup>(6)</sup>	-50 to 250	-58 to 482	3 °C (5.40 °F)	$\pm 0.15$	0.09 °C (0.16 °F)	$\pm 0.006$
Thermocouples <sup>(7)</sup>						
Type B <sup>(8)</sup> (9)	100 to 1820	212 to 3308	2.3 °C (4.05 °F)	$\pm 0.15$	0.084 °C (0.150 °F)	$\pm 0.006$
Type J <sup>(8)</sup>	-180 to 760	-292 to 1400	0.8 °C (1.35 °F)	$\pm 0.15$	0.03 °C (0.054 °F)	$\pm 0.006$
Type K <sup>(8)</sup> (10)	-180 to 1372	-292 to 2502	0.8 °C (1.35 °F)	$\pm 0.15$	0.03 °C (0.054 °F)	$\pm 0.006$
Type N <sup>(8)</sup>	-200 to 1300	-328 to 2372	1.2 °C (2.16 °F)	$\pm 0.15$	0.03 °C (0.054 °F)	$\pm 0.006$
Type R <sup>(8)</sup>	0 to 1768	32 to 3214	1.8 °C (3.24 °F)	$\pm 0.15$	0.09 °C (0.16 °F)	$\pm 0.006$
Type S <sup>(8)</sup>	0 to 1768	32 to 3214	1.5 °C (2.70 °F)	$\pm 0.15$	0.09 °C (0.16 °F)	$\pm 0.006$
2-, 3-, 4-wire Ohm Input	0 to 2000 ohms		1.1 ohm	$\pm 0.15$	0.042 ohm	$\pm 0.009$

(1) Input ranges are for transmitter only. Actual sensor (RTD or Thermocouple) operating ranges may be more limited. See "Sensor Specifications" on page 84 for temperature ranges.

(2) Change in ambient is with reference to the calibration temperature of the transmitter at 68 °F (20 °C) from factory.

(3) IEC 751, 1995

(4) JIS 1604, 1981

(5) Edison Curve No. 7

(6) Edison Copper Winding No. 15

(7) Total accuracy for thermocouple measurement: sum of accuracy +0.5 °C.

(8) NIST Monograph 175, IEC 584

(9) Fixed accuracy for NIST Type B is  $\pm 5.4\text{ }^\circ\text{F}$  ( $\pm 3.0\text{ }^\circ\text{C}$ ) from 212 to 572 °F (100 to 300 °C).

(10) Fixed accuracy for NIST Type K is  $\pm 1.3\text{ }^\circ\text{F}$  ( $\pm 0.7\text{ }^\circ\text{C}$ ) from -292 to -130 °F (-130 to -90 °C).

## Product Data Sheet

00813-0100-4148, Rev BA

May 2008

# Rosemount 148

---

### Transmitter Accuracy Example

When using a Pt 100 ( $a = 0.00385$ ) sensor input with a 0 to 100 °C span, use the greater of the two calculated values. In this case the accuracy would be  $\pm 0.3$  °C.

### Transmitter Temperature Effects Example

Transmitters can be installed in locations where the ambient temperature is between  $-40$  and  $85$  °C ( $-40$  and  $185$  °F). In order to maintain excellent accuracy performance, each transmitter is individually characterized over this ambient temperature range at the factory.

When using a Pt 100 ( $a = 0.00385$ ) sensor input with a 0–100 °C span at 30 °C ambient temperature:

- Temperature Effects:  $0.009$  °C  $\times$   $(30 - 20) = 0.09$  °C

### Total Transmitter Error

Worst Case Transmitter Error: Accuracy + Temperature Effects =  $0.3$  °C +  $0.09$  °C =  $0.39$  °C

Total Probable Transmitter Error:  $\sqrt{0.3^2 + 0.09^2} = 0.31$  °C

## Product Certifications

### APPROVED MANUFACTURING LOCATIONS

Rosemount Inc. – Chanhassen, Minnesota, USA  
Emerson Process Management Temperature GmbH – Germany  
Emerson Process Management Asia Pacific – Singapore

### EUROPEAN UNION DIRECTIVE INFORMATION

The EC declaration of conformity for all applicable European directives for this product can be found on the Rosemount website at [www.rosemount.com](http://www.rosemount.com). A hard copy may be obtained by contacting your local sales representative.

#### ATEX Directive (94/9/EC)

Rosemount Inc. complies with the ATEX Directive.

#### Electro Magnetic Compatibility (EMC) (89/336/EEC)

All Models: EN 50081-1: 1992; EN 50082-2:1995; EN 61326-1. 2006

#### CE Mark

The 148 meets all requirements listed under IEC 61326:Amendment 1,2006

### HAZARDOUS LOCATIONS CERTIFICATIONS<sup>(1)</sup>

#### North American Certifications

##### Factory Mutual (FM)

- I5 FM Intrinsic Safety and Non-incendive Intrinsically Safe for Class I/II/III, Division 1, Groups A, B, C, D, E, F, and G. Non-incendive Field Circuit for Class I, Division 2, Groups A, B, C, and D. Intrinsically Safe and non-incendive when installed in accordance with Rosemount drawing 00148-1055.

Temperature Codes:

T5 ( $T_{amb} = -50$  to  $75$  °C)

T6 ( $T_{amb} = -50$  to  $40$  °C)

TABLE 3. Entity Parameters

Loop/Power	Sensor
$U_i = 30$ Vdc	$U_o = 45$ Vdc
$I_i = 130$ mA	$I_o = 26$ mA
$P_i = 1.0$ W	$P_o = 290$ mW
$C_i = 3.6$ nF	$C_o = 0.4$ nF
$L_i = 13.8$ μH	$L_o = 49.2$ mH

- E5 FM Explosion-Proof Explosion-Proof for Class I, Division 1, Groups B, C, and D. Dust Ignition Proof for Class II/III, Division 1, Groups E, F, G when installed in accordance with Rosemount drawing 00148-1065.

Temperature Code:

T5 ( $T_{amb} = -40$  to  $85$  °C)

#### Combination Certifications

- K5 Combination of I5 and E5.

#### Canadian Standards Association (CSA) Approvals

- I6 CSA Intrinsically Safe and Class I, Division 2 Intrinsically Safe for Class I, Division 1, Groups A, B, C, and D when installed in accordance with Rosemount drawing 00148-1056.

Temperature Codes:

T5 ( $T_{amb} = -50$  to  $60$  °C)

T6 ( $T_{amb} = -50$  to  $40$  °C)

Suitable for use in Class I, Division 2, Groups A, B, C, and D.

- K6 CSA Intrinsically Safe, Explosion-Proof, and Class I, Division 2. Combination of I6 and Explosion-Proof for Class I, Division 1, Groups B, C, and D; Class II, Division 1, Groups E, F, and G; Class III, Division 1 hazardous locations, when installed in accordance with Rosemount drawing 00644-1059.

Suitable for Class I, Division 2, Groups A,B, C, and D. Ambient Temperature Limit:  $-50$  to  $85$ °C

#### European Certifications

- I1 ATEX Intrinsic Safety Certificate Number: See Certificate ATEX Marking:  II 1 G **CE** 1180 EEx ia IIC

Temperature Codes:

T5 ( $-60 \leq T_{amb} \leq 80$  °C)

T6 ( $-60 \leq T_{amb} \leq 60$  °C)

TABLE 4. Entity Parameters

Loop/Power	Sensor
$U_i = 30$ Vdc	$U_o = 45$ Vdc
$I_i = 130$ mA	$I_o = 26$ mA
$P_i = 1.0$ W	$P_o = 290$ mW
$C_i = 3.6$ nF	$C_i = 2.1$ nF
$L_i = 0$	$L_i = 0$

#### Special Conditions for Safe Use (X):

The apparatus must be installed in an enclosure which affords it a degree of protection of at least IP20.

Non-metallic enclosures must have a surface resistance of less than 1 GOHM; light alloy or zirconium enclosures must be protected from impact and friction when installed.

(1) Consult factory for availability.

# Product Data Sheet

00813-0100-4148, Rev BA

May 2008

# Rosemount 148

E1 ATEX Flame-Proof  
Certificate Number: See Certificate  
ATEX Marking:  $\text{II 2 G}$   
**CE** 1180  
EEx d IIC  
TABLE 5. Input Parameters  
 $U_{\text{max}} = 42.4 \text{ Vdc}$   
 $I_{\text{max}} = 24 \text{ mA}$   
Temperature Codes:  
T6 ( $-40 \leq T_{\text{amb}} \leq 65 \text{ }^\circ\text{C}$ )

N1 ATEX Type n  
Certificate Number: See Certificate  
ATEX Marking:  $\text{II 3}$   
EEx nL IIC  
TABLE 6. Input Parameters  
 $U_{\text{max}} = 45 \text{ V}$   
Temperature Codes:  
T5 ( $-40 \leq T_{\text{amb}} \leq 70 \text{ }^\circ\text{C}$ )

NC ATEX Type n Component  
Certificate Number: See Certificate  
ATEX Marking:  $\text{II 3G}$   
EEx nA IIC  
TABLE 7. Input Parameters  
 $U_i = 42.4 \text{ V}$   
 $C_i = 3.6 \text{ nF}$   
 $L_i = 0$   
Temperature Codes:  
T5 ( $-60 \leq T_{\text{amb}} \leq 80 \text{ }^\circ\text{C}$ )  
T6 ( $-60 \leq T_{\text{amb}} \leq 60 \text{ }^\circ\text{C}$ )

ND ATEX Dust Ignition Proof  
Certificate Number: See Certificate  
ATEX Marking:  $\text{II 1 D}$   
CE 1180  
T95 C ( $-40 \leq T_{\text{amb}} \leq 85 \text{ }^\circ\text{C}$ )  
IP66  
TABLE 8. Input Parameters  
 $U_{\text{max}} = 42.4 \text{ Vdc}$   
 $I_{\text{max}} = 24 \text{ mA}$

## Australian Certifications

Standard Australia Quality Assurance Service (SAA) Approvals

E7 SAA Explosion-Proof  
Certificate Number: See Certificate  
Ex d IIC  
Temperature Codes:  
T6 ( $-40 \leq T_{\text{amb}} \leq 65 \text{ }^\circ\text{C}$ )

### Special Conditions for Safe Use (X):

1. A thermowell must be utilized on installations incorporating a DIN style or a spring loaded sensor assembly, with all threaded connections sealed with sealing tape to maintain the IP rating of IP66/IP68 (3 meters).
2. When a gland is utilized on installation, the gland must be Standards Australia certified and must be capable of maintaining the IP rating. This also requires the use of thread sealing tape on all gland entries.

## Brazilian Certifications

Centro de Pesquisas de Energia Eletrica (CEPEL) Approval

I2 CEPEL Intrinsic Safety

## IECEx Certifications

I7 IECEx Intrinsic Safety (Zone 0)  
Certificate Number: See Certificate  
Ex nA nL IIC

Temperature Codes:  
T5 ( $T_{\text{amb}} = -40 \text{ }^\circ\text{C}$  to  $75 \text{ }^\circ\text{C}$ )

TABLE 9. Entity Parameters

Ex ia Terminals $\pm$	Sensor
$U_i = 30 \text{ Vdc}$	$U_o = 45 \text{ Vdc}$
$I_i = 130 \text{ mA}$	$I_o = 26 \text{ mA}$
$P_i = 1.0 \text{ W}$	$P_o = 290 \text{ mW}$
$C_i = 3.63 \text{ nF}$	$C_i = 10 \text{ nF}$
$L_i = 0 \text{ mH}$	$L_i = 26 \text{ mH}$

### Conditions of Certification:

1. It is a condition of safe use that the input entity parameters must be taken into account when connecting to a supply. For sensor output terminals, the sensor entity parameters shall be taken into account during installation.
2. It is a condition of safe use that the apparatus shall only be supplied from a galvanically isolated safety barrier with output current limited by a minimum 225 Ohms resistor.
3. It is a condition of safe use that the transmitter must be mounted in an enclosure that suits Group IIC application and affords a degree of protection of at least IP20 for Ex ia version, and of at least IP54 for Ex n version.
4. It is a condition of safe use that the apparatus shall be installed according to the installation drawing 00148-1057.

N7 IECEx Type n (Zone 2)  
Certificate Number: See Certificate  
Ex nA IIC

Temperature Codes:  
T5 ( $T_{\text{amb}} = -60 \text{ }^\circ\text{C}$  to  $70 \text{ }^\circ\text{C}$ )  
T6 ( $T_{\text{amb}} = -60 \text{ }^\circ\text{C}$  to  $50 \text{ }^\circ\text{C}$ )

TABLE 10. Ex n Input Parameters

Ex n Terminals $\pm$
$U_i = 45 \text{ V}$

## Dimensional Drawings

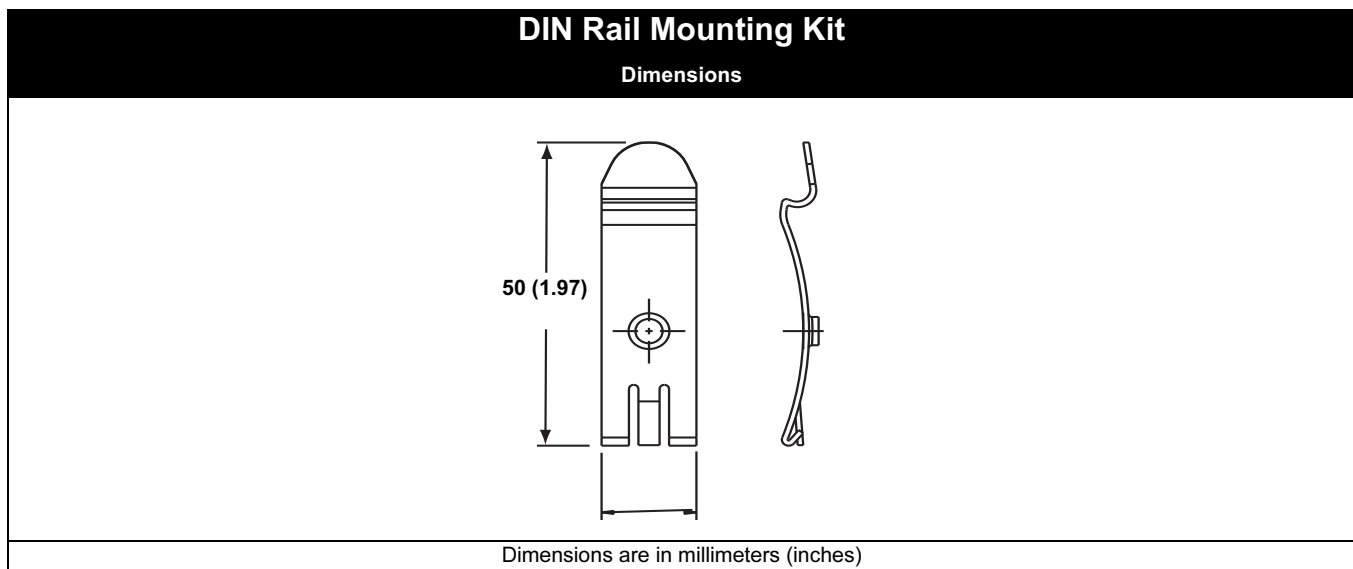
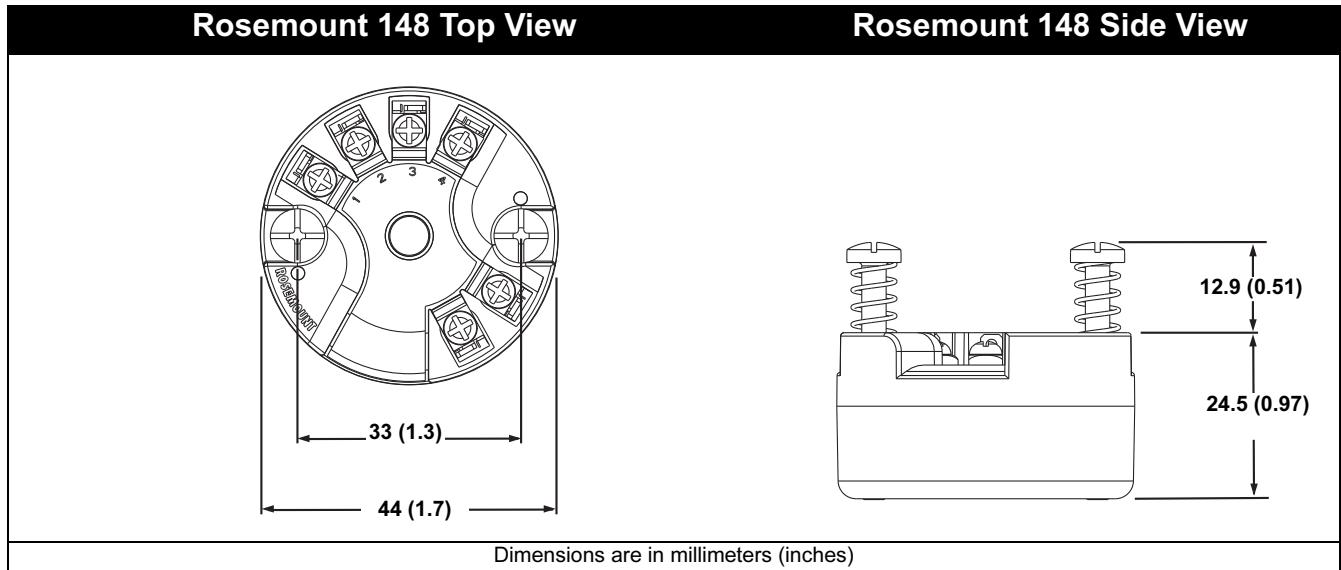

## Ordering Information

TABLE 11. Rosemount 148 PC-Programmable Temperature Transmitter

<b>Model</b>	<b>Product Description</b>
148	DIN B PC Programmable Head Mount Temperature Transmitter
<b>Code</b>	<b>Mounting Style</b>
H	Head Mount
<b>Code</b>	<b>Output Protocol</b>
N	Analog Output
<b>Code</b>	<b>Product Certifications</b>
I1	ATEX Intrinsic Safety
E1 <sup>(1)</sup>	ATEX Flameproof
N1	ATEX Type n
NC	ATEX Type n Component
ND <sup>(1)</sup>	ATEX Dust Ignition Proof
I5	FM Intrinsic Safety and Class 1, Division 2
E5 <sup>(1)</sup>	FM Explosion-Proof
K5 <sup>(1)</sup>	FM Intrinsic Safety, Explosion-Proof, and Class 1, Division 2
I6	CSA Intrinsic Safety and Class 1, Division 2
K6 <sup>(1)</sup>	CSA Intrinsic Safety, Explosion-Proof, and Class 1, Division 2
I7	IECEX Intrinsic Safety
E7 <sup>(1)</sup>	SAA Flameproof
N7	IECEX Type N
NA	No approvals
<b>Code</b>	<b>Enclosure Options</b>
U	Universal Head (Junction Box), IP68, Aluminum
H	Universal Head (Junction Box), IP68, SST
N	No Enclosure
<b>Code</b>	<b>Cable/Conduit Entry</b>
1	M20 x 1.5
2	1/2-inch NPT
0	No Enclosure
<b>Code</b>	<b>Analog Output</b>
A1	Analog output levels compliant with NAMUR-recommendation NE 43: high alarm
CN	Analog output levels compliant with NAMUR-recommendation NE 43: low alarm
<b>Code</b>	<b>Line Voltage Filter</b>
F5	50 Hz line voltage filter
F6	60 Hz line voltage filter
<b>Code</b>	<b>External Ground Option (Available w/Enclosures U, H)</b>
G1	External Ground Lug Assembly
<b>Code</b>	<b>Cover Chain Option (Available w/Enclosures U, H)</b>
G3	Cover Chain
<b>Code</b>	<b>Conduit Entry Options</b>
G2	Cable Gland—Explosion Proof—7.5 mm - 11.9 mm
G4	Cable Gland—Explosion Proof, Thin Wire - 3.0 mm - 8.0 mm
GE	Eurofast Interlinkbt Connector
GM	Minifast Interlinkbt Connector
<b>Code</b>	<b>Assemble-to Options</b>
XA	Sensor Specified Separately and Assembled to Transmitter
<b>Typical Model Number: 148 H N I5 U1 A1 XA</b>	

<sup>(1)</sup> Approval Codes E1, ND, E5, K5, K6, and E7 require an enclosure

# Rosemount 148

## Rosemount 148 PC Programmer

The Rosemount 148 PC Programmer is a portable, self-contained communication link between your PC and the 148 transmitter for use in non-hazardous environments. The 148 PC Programmer contains the following items:

- PC Programmer Unit
- Programming Software (CD-ROM)
- 9V Battery
- Transmitter Connectors

## Rosemount 148 PC Programmer Software

The software makes the following parameters available:

- Process Variable
- Sensor Type
- Number of Wires
- Engineering Units
- Transmitter Tag Information)
- Damping
- Alarming Parameters

To order the 148 PC Programmer, use Part Number 00148-1601-0001.

**TABLE 12. Rosemount 148 Transmitter Accessories**

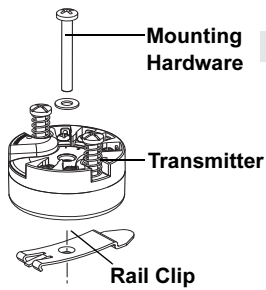

External Ground Screw Assembly Kit	00644-4431-0001
Kit, Hardware for Mounting a 148 to a DIN Rail (see left picture-top hat rail, symmetric)	00248-1601-0001
Snap Rings Kit (used for assembly to DIN Plate Style sensor)	00644-4432-0001



# Rosemount 148

**Product Data Sheet**  
00813-0100-4148, Rev BA  
May 2008

*The Emerson logo is a trademark and service mark of Emerson Electric Co.  
Rosemount and the Rosemount logotype are registered trademarks of Rosemount Inc.  
PlantWeb is a registered trademark of one of the Emerson Process Management group of companies.  
Eurofast and Minifast are registered trademarks of Turck Inc.  
All other marks are the property of their respective owners.*

*Standard Terms and Conditions of Sale can be found at [www.rosemount.com/terms\\_of\\_sale](http://www.rosemount.com/terms_of_sale)*

## **Emerson Process Management**

### **Rosemount Inc.**

8200 Market Boulevard  
Chanhassen, MN 55317 USA  
T (U.S.) 1-800-999-9307  
T (International) (952) 906-8888  
F (952) 949-7001

### **Emerson Process Management**

Blegistrasse 23  
P.O. Box 1046  
CH 6341 Baar  
Switzerland  
T +41 (0) 41 768 6111  
F +41 (0) 41 768 6300

### **Emerson FZE**

P.O. Box 17033  
Jebel Ali Free Zone  
Dubai UAE  
T +971 4 883 5235  
F +971 4 883 5312

### **Emerson Process ManagementAsia Pacific Pte Ltd**

1 Pandan Crescent  
Singapore 128461  
T +65 6777 8211  
F +65 6777 0947  
Service Support Hotline: +65 6770 8711  
Email: [Enquiries@AP.EmersonProcess.com](mailto:Enquiries@AP.EmersonProcess.com)

