

## Supplement ATEX Safety Instructions

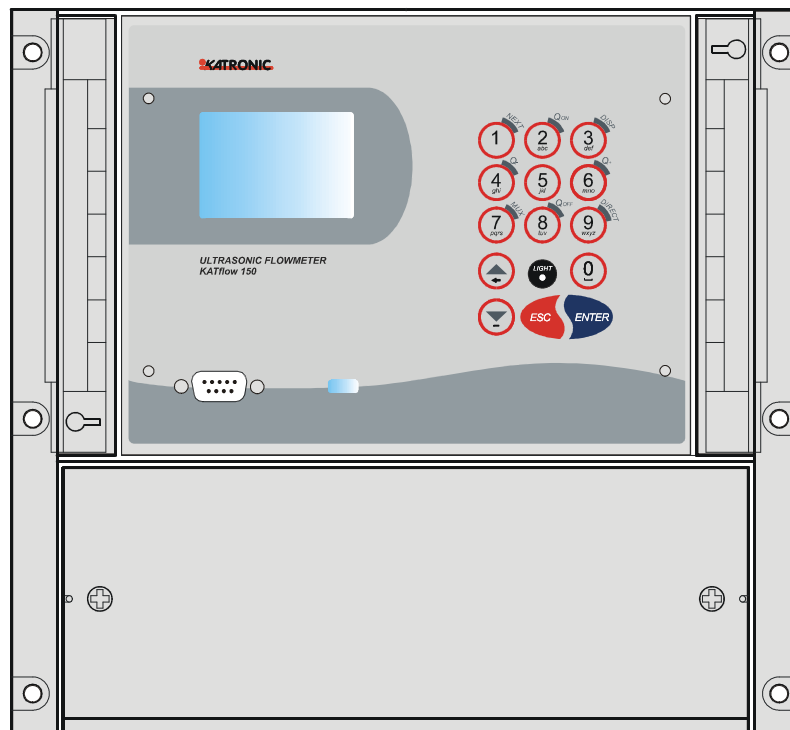

### Ultrasonic Flowmeter **KATflow 150**

including Transducers Type K1Ex and K4Ex  
for use in hazardous areas Zone 0, 1 and 2

**Note:** These instructions are an extension to the  
KF150 Operating Instructions

**Katronic Technologies Ltd.**

23 Cross Street  
Leamington Spa  
Warwickshire CV32 4PX  
United Kingdom

*Tel.* +44 (0)1926 882954

*Fax* +44 (0)1926 338649

*Internet* [www.katronic.co.uk](http://www.katronic.co.uk)

*E-mail* [mail@katronic.co.uk](mailto:mail@katronic.co.uk)

**Supplement Safety Instructions  
KATflow 150 and K1Ex/K4Ex**

Version V10E1109

Copyright © 2009

All rights reserved.

# KATflow 150 and K1Ex/K4Ex Supplement Safety Instructions

## Table of Content

	Page
<b>1 Safety instructions</b> .....	<b>6</b>
1.1 Symbols used in these operating instructions.....	6
1.2 Safety instructions for the operator.....	7
1.3 Languages/translations.....	7
1.4 Warranty.....	7
1.5 Return policy.....	7
1.6 Legislative requirements.....	8
<b>1 Introduction</b> .....	<b>9</b>
1.1 System configurations.....	9
1.2 Approvals.....	10
1.2.1 <i>Clamp-on ultrasonic sensors</i> .....	10
1.2.2 <i>Flow transmitter</i> .....	11
1.3 Temperature Limits.....	11
1.3.1 <i>Clamp-on ultrasonic sensors</i> .....	11
1.3.2 <i>Transmitter</i> .....	11
1.4 Special conditions of safe use.....	12
1.5 EC type examination certificates.....	12
<b>2 Installation</b> .....	<b>13</b>
2.1 Sensor installation in the hazardous area.....	13
2.2 Transmitter installation in the safe area.....	13
2.3 Transmitter installation in the hazardous area.....	13
<b>3 Electrical installation</b> .....	<b>14</b>
3.1 Cabling and junction box.....	15
3.1.1 <i>Signal cable parameters</i> .....	16
3.2 Cable glands.....	16
3.3 Equipotential bonding.....	16
3.3.1 <i>Clamp-on ultrasonic sensors</i> .....	16
3.3.2 <i>Transmitter</i> .....	16
3.4 Process inputs/outputs.....	16
<b>4 Maintenance</b> .....	<b>17</b>
4.1 Opening/closing KF150-Exd door.....	17
4.2 Service/Repair.....	17
4.3 Customer Return Note (CRN).....	18
<b>5 Technical data</b> .....	<b>19</b>
5.1 K1Ex and K4Ex clamp-on ultrasonic sensors.....	19
5.2 KF150 transmitter.....	19
<b>6 Certificate of Conformity</b> .....	<b>20</b>

# 1 Safety instructions

## 1.1 Symbols used in these operating instructions



### Danger

This symbol represents an immediate hazardous situation which could result in **serious injury, death** or **damage to the equipment**. Where this symbol is shown, do not use the equipment further unless you have fully understood the nature of the hazard and have taken the required precautions.



### Danger

This warning refers to an immediate danger when using the equipment in a hazardous area.



### Attention

This symbol indicates important instructions which should be respected in order to avoid damaging or destroying the equipment. Follow the the precautions given in these instructions to avoid the hazard. Call our service team if necessary.



### Call service

Where this symbol is shown call our service team for advice if necessary.



### Note

This symbol indicates a note or detailed set-up tip.



Information point.



Operator keys are printed in bold typeface and placed in pointed brackets.

## 1.2 Safety instructions for the operator

These supplement instructions are provided in addition to the KF150 Operating Instructions and are only applicable for sensor and optionally transmitter installations in hazardous areas.



- Do not install, operate or maintain this flowmeter without reading, understanding and following the operating instructions, otherwise injury or damage may result.
- Study these operating instructions carefully before the installation of the equipment and keep them for future reference.
- Observe all warnings, notes and instructions as marked on the packaging of the equipment and detailed in the operating instructions.
- Do not change or alter the sensors or the transmitter. Unauthorized changes affect the explosion safety of the equipment.
- The special conditions of use as described in the EC type examination certificate must be followed. In addition, all given electrical specifications must be met.
- The electrical installation must be in accordance with applicable national standards (equivalent to IEC 364) in addition to the requirements for installation in hazardous areas according to EN 60079-14 "Electrical installations in hazardous locations" or equivalent national standards.
- Installation, operation, service and maintenance of the equipment must only be performed by authorised and trained personnel with the necessary knowledge and qualifications in explosion safety.
- If the product does not operate normally, please refer to the service and troubleshooting instructions, or contact KATRONIC for help.

## 1.3 Languages/translations

These safety instructions are compiled in English. If English is not your native language and you have difficulties understanding the content of these instructions, please contact KATRONIC and/or your authorised local distributor for a translation of this text.

## 1.4 Warranty

- Any product purchased from KATRONIC is warranted in accordance with the relevant product documentation and as specified in the sales contract provided it has been used for the purpose for which it has been designed and operated as outlined in the operating instructions. Misuse of the equipment will immediately revoke any warranty given or implied.
- Responsibility for suitability and intended use of this ultrasonic flowmeter rests solely with the user. Improper installation and operation of the flowmeter may lead to a loss of warranty.
- Please note that there are no operator-serviceable parts inside the equipment. Any unauthorised interference with the product will invalidate the warranty.

## 1.5 Return policy

If the flowmeter has been diagnosed to be faulty, it can be returned to KATRONIC for repair using the Customer Returns Note (CRN), a copy of which can be found in chapter 4.3 of this manual. KATRONIC regret that for Health & Safety reasons we cannot accept the return of the equipment unless accompanied by the completed CRN.

## 1.6 Legislative requirements

### **CE marking**

The flowmeter is designed to meet the safety requirements in accordance with sound engineering practice. It has been tested and has left the factory in a condition in which it is safe to operate. The equipment is in conformity with the statutory requirements of the EC directive and complies with applicable regulations and standards for electrical safety EN 61010, hazardous area equipment 94/9 EC (ATEX100a) and electro-magnetic compatibility EN 61326. A CE Declaration of Conformity has been issued in that respect, a copy of which can be found in chapter 6 of these operating instructions.

### **WEEE Directive**

The Waste Electrical and Electronic Equipment Directive (WEEE Directive) aims to minimise the impact of electrical and electronic goods on the environment by increasing re-use and recycling and by reducing the amount of WEEE going to landfill. It seeks to achieve this by making producers responsible for financing the collection, treatment, and recovery of waste electrical equipment, and by obliging distributors to allow consumers to return their waste equipment free of charge.



KATRONIC offers its customers the possibility of returning unused and obsolete equipment for correct disposal and recycling. The Dustbin Symbol indicates that when the last user wishes to discard this product, it must be sent to appropriate facilities for recovery and recycling. By not discarding this product along with other household-type waste, the volume of waste sent to incinerators or landfills will be reduced and natural resources will be conserved. Please use the Customer Return Note (CRN) in chapter 4.3 for return to KATRONIC.

### **RoHS Directive**

The European Union's RoHS ("Restriction of the use of certain Hazardous Substances") Directive (2002/95/EC) came into effect on July 1, 2006. All of the instrumentation manufactured by KATRONIC falls under Category 9, Measurement and Control Equipment. Currently this category is exempt from RoHS compliance until at least 2010, when it and other exemptions will be reviewed. Regardless of this, all products manufactured by KATRONIC are compliant with the RoHS Directive.

# 1 Introduction

## Clamp-on transit-time flowmeter

The KATflow 150 is a fixed installation ultrasonic flowmeter employing clamp-on sensors for the measurement of liquids in full, enclosed pipes. Flow measurements can be undertaken without interruption of the process or interference with the integrity of the pipeline. The clamp-on sensors are attached to the outside of the pipes. The KATflow 150 uses ultrasonic signals for measurement of the flow, employing the transit-time method. The sensor types K1Ex and K4Ex have been specifically designed for use in hazardous areas. The flow transmitter KF150 is available in different enclosure formats for installation in safe or in hazardous areas.

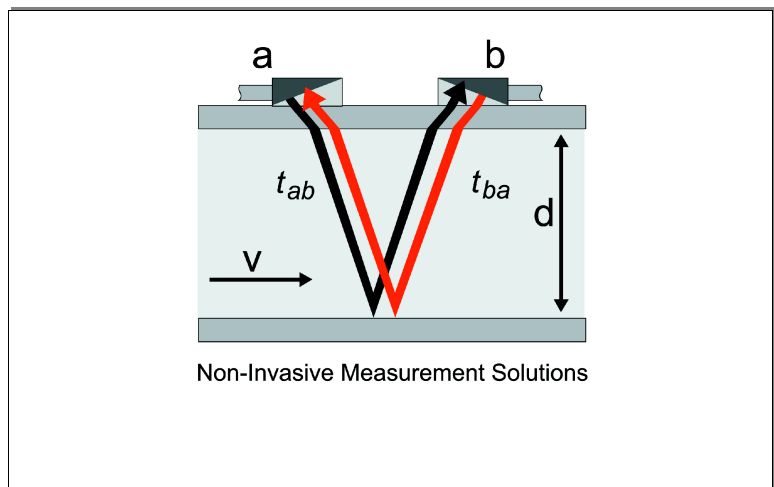

Illustration 1: Clamp-on ultrasonic flowmeter principle

### 1.1 System configurations



Only the sensor types K1Ex and K4Ex can be installed in the hazardous area Zone 0,1 or 2. The KATflow 150 flow transmitter with standard ABS housing must be located in the safe area.

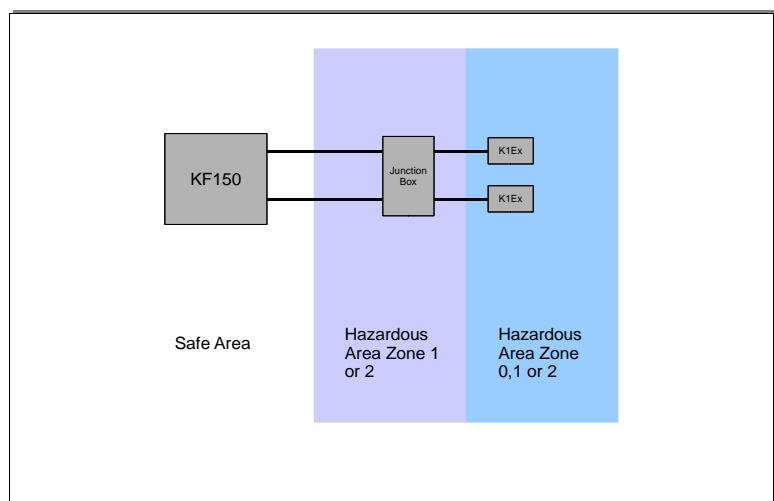

Illustration 2: Configuration Ex-sensors and KF150 in safe area

If the KATflow 150 flow transmitter is housed in a explosion-proof enclosure type CCFE, then the transmitter can be installed in hazardous areas 1 or 2.

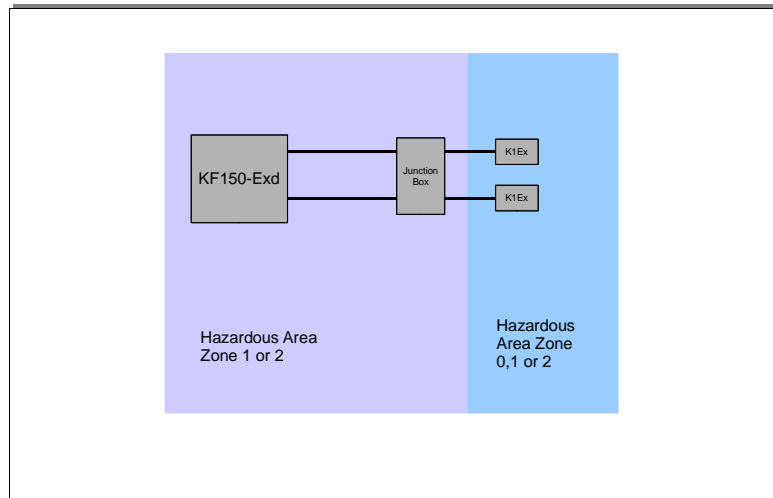

Illustration 3: Configuration Ex-sensors and KF150-Exd in hazardous area

## 1.2 Approvals

### 1.2.1 Clamp-on ultrasonic sensors

The clamp-on ultrasonic sensors are manufactured according to the European Directive 94/9/EC (ATEX100a). The equipment is approved for installation and use in hazardous classified areas of Zone 0, 1 and 2 by the certification agency TRaC (ATEX notified body identification 0891). The protection concept for the sensors is “encapsulation” as per EN 60079-18.

The K1Ex, K4Ex transducers meet the requirements of the following standards:

Standard	Description
EN 60079-0:2006	Electrical equipment for use in explosive atmosphere – General requirements
EN 60079-18:2004	Electrical equipment for use in explosive atmosphere – Encapsulation “m”
EN 61241-0:2006	Electrical equipment for use in the presence of combustible dust – General requirements
EN 61241-18:2004	Electrical equipment for use in the presence of combustible dust – Protection by enclosures “tD”

Certificate number of the sensors

K1Ex and K4Ex ultrasonic sensors

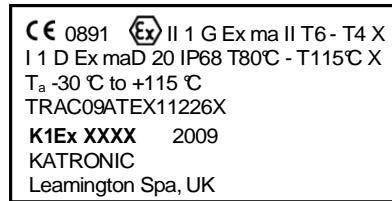
**TRAC 09 ATEX 11226 X**Certification label**1.2.2 Flow transmitter**

The flowmeter KATflow 150 in its standard ABS enclosure format **must be placed in the safe area**. K1Ex and K4Ex sensors which are located in the hazardous area Zone 0, 1 or 2 are connected to the KATflow 150 transmitter either directly or through an Ex certified junction box with cables provided by KATRONIC.

The KATflow 150 electronics can be mounted in an Ex d certified explosion-proof housing in which case the installation of the transmitter is allowed in hazardous areas classified as Zone 1 and 2. The protection concept for the KF150-Exd version is "explosion-proof" as per EN 60079-1.

Certificate of the Ex d control unit (KF150-Exd)

KATflow 150

in CCFE-3B-1510 type Ex d enclosure

**CESI 01 ATEX 027**Certification label*Drawing to go here***1.3 Temperature Limits****1.3.1 Clamp-on ultrasonic sensors**

The K1Ex and K4Ex clamp-on ultrasonic sensors can be used for the following process temperatures depending on the Temperature Class specified for the application:

Gas groups:

Temperature Class	Process temperature range
T6	-30 ... +80 °C
T5	-30 ... +95 °C
T4	-30 ... +115 °C

Dust groups:

The ambient temperature is the limiting factor but cannot exceed 115 °C therefore the max. temperature is T80°C - T115°C.

**1.3.2 Transmitter**

For the standard KF150 transmitter located in the safe area the ambient temperature range is -10 ... 60 °C.

The KF150-Exd transmitter for installation in hazardous area zones 1 and 2 can be used at ambient temperatures between -20 ... 40 °C.

#### 1.4 Special conditions of safe use



- The transducer must only be used in conjunction with the KATflow 150 transmitter (as defined in the certificate).
- The transducer must be securely fixed to the pipe to protect the PEEK surface of the sensors from mechanical impact and electrostatic charging.
- Where the interconnecting cable may be subject to mechanical damage then the user shall provide additional mechanical protection.

#### 1.5 EC type examination certificates

See ATEX documentation pack, copies attached.

## 2 Installation

This chapter refers to the mechanical installation of the clamp-on ultrasonic sensors and the transmitter unit.

### 2.1 Sensor installation in the hazardous area



**DANGER**

*The transducer must be securely fixed to the pipe to protect the PEEK surface of the sensors from mechanical impact and electrostatic charging.*

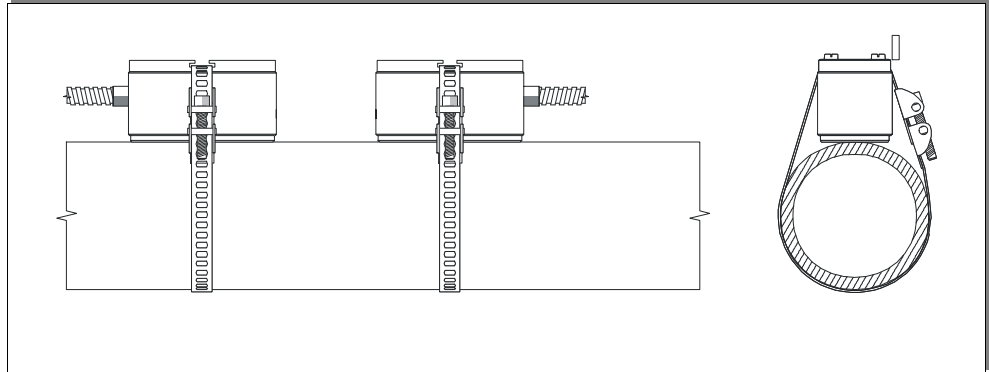

Illustration 4: Sensor mounting with tension straps and clamps

### 2.2 Transmitter installation in the safe area

Please refer to the standard “Operating Instructions KATflow 150”.

### 2.3 Transmitter installation in the hazardous area

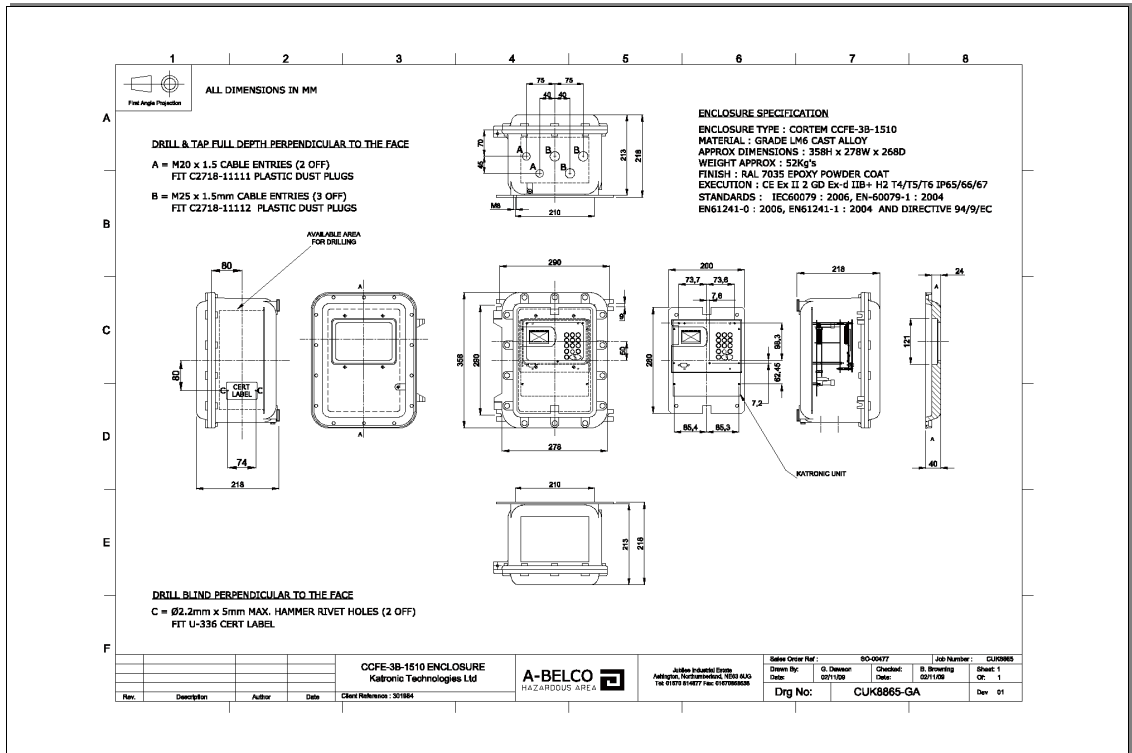

Illustration 5: Outline dimensions KF150-Exd transmitter

### 3 Electrical installation

The wiring of the equipment must be in accordance with the requirements as specified in the relevant national or international standard for electrical installations in hazardous areas, e.g. EN 60079-14. Section 9 (wiring systems) of this standard applies to all protection concepts. Section 10 (additional requirements for protection concept "d" - explosion-proof enclosures) and section 11 (additional requirements for protection concept "e" - increased safety).

Please note that in order to supply the unit with MAINS POWER, the equipment must be protected by suitably sized switches and circuit breakers.

#### *Electrical wiring*



100 ... 200 V AC, 50/60 Hz	10 W
9 ... 36 V DC	10 W

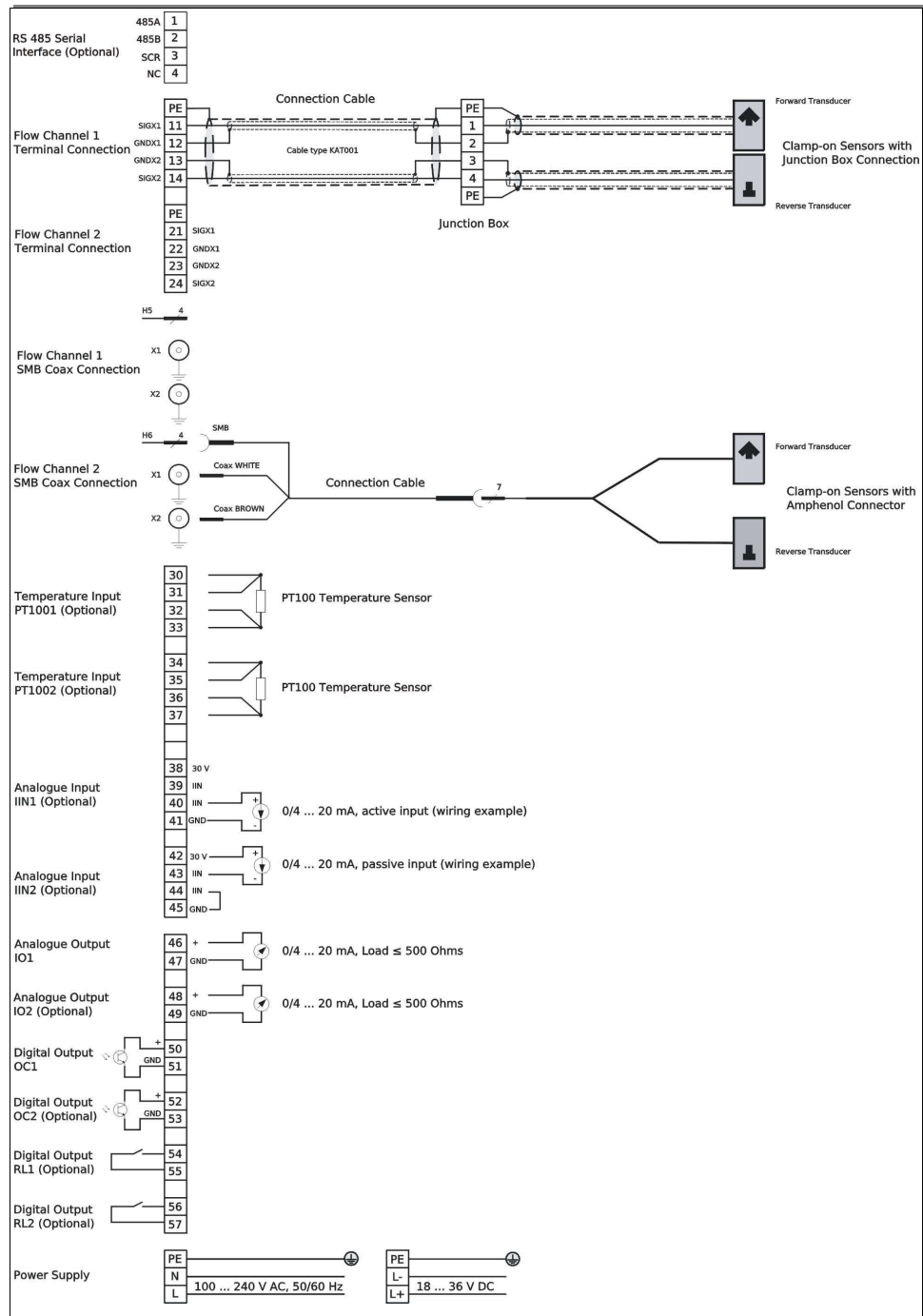

Drawing 1: Electrical connection diagram for the KATflow 150 flowmeter

### 3.1 Cabling and junction box

The hazardous area sensors K1Ex and K4Ex are manufactured with a standard cable length of 5 m. If this cable length is sufficient for the application, then the sensors can be terminated directly to the flow transmitter (direct cable connection).

For installations requiring longer cable lengths, the sensors are terminated at an Ex e (increased safety) certified junction with approved terminals.

The electrical connection between the junction box and the flow transmitter (signal cabling) is established with special dual coax cable type KAT01. The cable ends of the coaxial cables must be terminated with suitable sized ferrules. The signal cable is provided with the system. The max. recommended signal cable length is 100 m.



**DANGER**

*Where the interconnecting sensor and/or signal cable may be subject to mechanical damage then the user shall provide additional mechanical protection.*

### 3.1.1 Signal cable parameters

The signal cable supplied with the instrument has the following parameters:

Total attenuation	0.021 dB/m
Capacitance (core/screen)	107 pF/m
Inductance (core/screen)	0.24 µH/m

### 3.2 Cable glands

The KF150-Exd housing features 2 x M20 cable entries for the sensor/signal cabling and 3 x M25 cable entries for power supply and process input/output connections.



The KF150-Exd transmitter housing is supplied with plastic dust caps. The temporary plugs are only intended for sealing the equipment against entry of dust, moisture or other possible ingress during transport, handling and storage. These dust caps must be replaced by suitable Ex d approved cable glands, stopping plugs or conduit adapters with respective sealing before the flowmeter is put into operation.

The installer is responsible for the correct sizing and selection of the Ex d approved cable glands for the explosion-proof box. Unused cable entries must be closed with suitable Ex d blind plugs.

Ex d approved cable glands/blind plugs are not part of the standard delivery package and must be provided by the customer or explicitly ordered from KATRONIC.

### 3.3 Equipotential bonding

#### 3.3.1 Clamp-on ultrasonic sensors

The K1Ex and K4Ex sensors feature a terminal connection which must be used to connect the transducers to the equipotential bonding system locally.

#### 3.3.2 Transmitter

The KATflow 150 flow transmitter must always be incorporated to the equipotential bonding system of the installation in the hazardous area. For this purpose it must be connected to the internal U-clamp screw terminal inside the wall mounted enclosure. The explosion-proof box KF150-Exd additionally features a screw terminal outside of the housing, which must be earthed locally.

The earthing conductor must be at least 4 mm<sup>2</sup> (11 AWG) or 2.5 mm<sup>2</sup> (14 AWG) in case it is mechanically protected as per IEC 364-4-41.

### 3.4 Process inputs/outputs

If the process inputs/outputs are to be terminated in the hazardous area, the associated equipment must be certified accordingly.



## 4 Maintenance

The KATflow 150 flowmeter are maintenance free concerning the flow measurement functions. Within the scope of periodic inspections required for electrical equipment installed in hazardous areas it is recommended to check the transducers, junction box if installed and the explosion-proof transmitter housing for signs of damage or corrosion.

### 4.1 Opening/closing KF150-Exd door



#### **DANGER**

***The following instructions must always be carefully followed, if the housing of the KF150-Exd transmitter must be opened respectively closed again.***

Before opening:

- Make absolutely sure that there is no explosion hazard!
- A gas-free certificate and a valid work permit must be obtained before commencing work!
- Make sure that all connecting cables are safely isolated from all external sources!
- Allow the electronics to de-energize before opening the electronics compartment of the explosion-proof housing. **Wait at least 10 minutes before opening.**

When the instructions above are strictly followed, the door of the explosion-proof housing may be opened. Unscrew the head screws with suitable Allen keys until the door can be opened.

Closing:

- Screw the head screws back and tighten them firmly with a suitable Allen key. Make sure the door is closed properly.

### 4.2 Service/Repair

The KATflow 150 flowmeter has been carefully manufactured and tested. If installed and operated in accordance with the operating instructions, no problems are usually experienced.

Should you nevertheless need to return a device for inspection or repair, please pay attention to the following points:

- Due to statutory regulations on environmental protection and safeguarding the health and safety of our personnel, the manufacturer may only handle, test and repair returned devices that have been in contact with products without risk to personnel and environment.
- This means that the manufacturer can only service this device if it is accompanied by a Customer Return Note (CRN) confirming that the device is safe to handle.

If the device has been operated with toxic, caustic, flammable or water-endangering products, you are kindly requested:

- to check and ensure, if necessary by rinsing or neutralising, that all cavities are free from such dangerous substances,
- to enclose a certificate with the device confirming that is safe to handle and stating the product used.

### 4.3 Customer Return Note (CRN)

#### Customer Return Note (CRN)



Company  Address   
Name   
Tel. No.   
E-mail

Instrument model  Katronic contract no.   
Serial number  (if known)

Sensor type(s)   
Sensor serial number(s)

The enclosed instrument has been used in the following environment (please ✓):

Nuclear radiation   
Water-endangering   
Toxic   
Caustic   
Biological   
Other (please specify)

We confirm (\* delete if not applicable)

- that we have checked the instrument and sensors are free of any contamination\*,
- neutralised, flushed and decontaminated all parts which have been in contact with hazardous substances and/or environments\*,
- that there is no risk to man or environment through any residual material.

Date   
Signature   
Company stamp

## 5 Technical data

### 5.1 K1Ex and K4Ex clamp-on ultrasonic sensors

Manufacturer	Katronic Technologies Ltd. 23 Cross Street Leamington Spa Warwickshire CV32 4PX UNITED KINGDOM
Marking	<i>Gas groups</i> II 1 G Ex ma II T6 - T4 X  <i>Dust groups</i> I 1 D Ex maD 20 IP68 T80°C - T115°C X
Certificate number	TRAC 09 ATEX 11226 X
Degree of protection	IP66, IP67 or IP68 according to EN 60529
Temperature limits	Temperature class T4: -30 ... +115 °C Temperature class T5: -30 ... +95 °C Temperature class T6: -30 ... +80 °C

### 5.2 KF150 transmitter

Safe area use	Model KF150
Hazardous area use	Model KF150-Exd
Manufacturer	<i>KF150</i> Katronic Technologies Ltd. 23 Cross Street Leamington Spa Warwickshire CV32 4PX UNITED KINGDOM  <i>KF150-Exd</i> A-Belco Group Jubilee Industrial Estate Ashington Northumberland NE63 8UG United Kingdom
Marking	<i>Gas groups</i> II 2 G EEx d IIB T6
Certificate number	CESI 01 ATEX 027
Degree of protection	IP66 according to EN 60529
Temperature limits	Temperature class T6: -20 ... +40 °C

## 6 Certificate of Conformity

### EC DECLARATION OF CONFORMITY

Declaration No. 01/2009

*We, the undersigned:*

*Name of Manufacturer*      Katronic Technologies Ltd.  
*Address*                      23 Cross Street  
                                       Leamington Spa  
                                       Warwickshire  
                                       CV32 4PX  
*Countr:*                        United Kingdom

*declare under our sole responsibility that the following apparatus:*

*Product description*      Clamp-on ultrasonic sensors and flowmeter  
*Model or Type No.*        Sensor types K1Ex, K4Ex and model KF150  
*Brand name*                 KATflow

*are in conformity with the following relevant EC legislation:*  
 ATEX directive 94/9/EC

Based on the following harmonised standards:

EN 60079-0:2006  
 EN 60079-18:2004  
 EN 60079-26:2004  
 EN 61241-0:2006  
 EN 61241-18:2004

*and therefore complies with all of the relevant essential requirements of those directives.*

*The following Notified Body has been involved in the conformity assessment process:*

*Notified Body*                TRaC EMC & Safety Ltd  
*Notified Body No.*         0891  
*Role*                            Issue of ATEX EC Type Examination certificate  
*Certificate No.*              TRAC 09 ATEX 11226 X

*Additional information:*

*ATEX coding*                Gas groups  
                                       II 1 G Ex ma II T6 - T4 X  
                                       Dust groups  
                                       I 1 D Ex maD 20 IP68 T80°C - T115°C X

*Technical File No.*

*Name and position of person binding the manufacturer or authorised representative:*

*Signature*



*Name*                            Karsten Frahn  
*Function*                     Director  
*Location*                    Leamington Spa  
*Date of issue*                12/11/2009