

Product Data Sheet

PS-00629, Rev. F
December 2007

Micro Motion® F-Series Coriolis Flow and Density Meters

Micro Motion® F-Series Coriolis meters offer highly accurate mass flow, volume flow, and density measurement in a compact design. F-Series meters come with a smooth exterior finish that can easily be kept clean, and all F-Series meters can be installed to be self-draining.

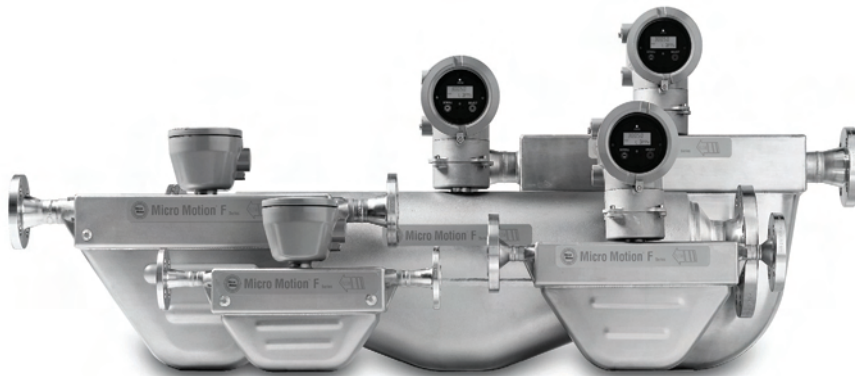

Best flow and density measurement in a compact, drainable flow meter

- Superior sensitivity in a compact design to reduce variability in process control
- Cleanable self-draining design enables fast product change-over

Broadest range of application coverage

- Low operating frequency for better measurement in continuous two-phase flow and gas applications
- Stainless steel or nickel alloy construction for a wide variety of process fluids
- High temperature and pressure options for extreme conditions

Superior reliability and safety

- IEC 61508 certified for SIL 2 and SIL 3 to simplify safety systems compliance
- No moving parts to wear or replace minimizes maintenance for long-term reliability

ELITE® Peak performance Coriolis meter

F-Series High performance compact drainable Coriolis meter

H-Series Hygienic compact drainable Coriolis meter

T-Series Straight tube full-bore Coriolis meter

R-Series General purpose flow-only Coriolis meter

LF-Series Extreme low-flow Coriolis meter



Micro Motion F-Series flow and density meters

Micro Motion Coriolis meters meet a vast range of application needs, ranging from extreme low-flow up to high-flow, high-capacity lines. Cryogenic, hygienic, high-temperature, and high-pressure— Micro Motion meters can handle them all. Micro Motion meters are available with a variety of wetted parts to ensure the best material compatibility.

Coriolis meters. Coriolis meters offer dramatic benefits over traditional volumetric measurement technologies. Coriolis meters:

- Deliver accurate and repeatable process data over a wide range of flow rates and process conditions.
- Provide direct inline measurement of mass flow and density, and also measure volume flow and temperature—all from a single device.
- Have no moving parts, so maintenance costs are minimal.
- Have no requirements for flow conditioning or straight pipe runs, so installation is simplified and less expensive.
- Provide advanced diagnostic tools for both the meter and the process.

F-Series Coriolis meters. Micro Motion F-Series Coriolis meters have a compact design that fits into tight spaces while offering highly accurate flow and density measurement for virtually any process fluid. With F-Series meters, expensive recalibrations become a thing of the past—a single F-Series calibration is valid for liquids, gases, and slurries.

The accumulated knowledge of Micro Motion is built into every F-Series meter. F-Series meters are available with either stainless steel or nickel-alloy wetted parts, allowing you to choose the material that is most compatible with your process fluid. And certain F-Series models are available for high-temperature and high-pressure applications.

Contents

Liquid flow performance	3	Hazardous area classifications	10
Density performance (liquid only)	4	Materials of construction	17
Gas flow performance	5	Weight	17
Temperature specifications	7	Dimensions	18
Pressure ratings	8	Fitting options	24
Vibration limits	8	Ordering information	30
Environmental effects	9		

Liquid flow performance

		Mass	Volume ⁽¹⁾
		kg/h	l/h
Maximum flow rate	F025	2720	2720
	F050	8160	8160
	F100	32650	32650
	F200	87100	87100
	F300	272000	272000
Mass flow accuracy⁽²⁾	Transmitter with MVD™ technology	±0,10% of rate ⁽³⁾⁽⁴⁾	
	All other transmitters ⁽⁵⁾	±0,20% of rate ±[(zero stability / flow rate) × 100]% of rate	
Volume flow accuracy⁽²⁾	Transmitter with MVD technology	±0,15% of rate ⁽⁶⁾⁽⁷⁾	
Repeatability	Transmitter with MVD technology	±0,05% of rate ⁽³⁾	
	All other transmitters ⁽⁵⁾	±0,10% of rate ±[½(zero stability / flow rate) × 100]% of rate	
		kg/h	l/h
Zero stability	F025	0,1765	0,1765
	F050	0,544	0,544
	F100	2,177	2,177
	F200	6,965	6,965
	F300	21,76	21,76

(1) Volumetric measurement is based on a process-fluid density of 1000 kg/m³. For fluids with density other than 1000 kg/m³, the volume flow rate equals the mass flow rate divided by the fluid's density.

(2) Stated flow accuracy includes the combined effects of repeatability, linearity, and hysteresis.

(3) When flow rate < (zero stability / 0,001), then mass flow accuracy = ±[(zero stability / flow rate) × 100]% of rate and repeatability = ±[½(zero stability / flow rate) × 100]% of rate.

(4) When ordered with the 0,15% calibration option, mass flow accuracy on liquid = ±0,15% when flow rate ≥ (zero stability / 0,0015). When flow rate < (zero stability / 0,0015), then accuracy = ±[(zero stability / flow rate) × 100]% of rate. When ordered with the 0,20% calibration option, mass flow accuracy on liquid = ±0,20% when flow rate ≥ (zero stability / 0,0020). When flow rate < (zero stability / 0,0020), then mass flow accuracy on liquid = ±[(zero stability / flow rate) × 100]% of rate.

(5) Model F300 sensors are compatible only with transmitters with MVD technology.

(6) When flow rate < (zero stability / 0,001), then volume flow accuracy on liquid = ±[1,5 × (zero stability / flow rate) × 100]% of rate and repeatability = ±[½(zero stability / flow rate) × 100]% of rate.

(7) When ordered with the ±0,15% calibration option, volume flow accuracy on liquid = ±0,25% when flow rate ≥ (zero stability / 0,0017). When flow rate < (zero stability / 0,0017), then volume accuracy on liquid = ±[1,5 × (zero stability / flow rate) × 100]% of rate. When ordered with the ±0,20% calibration option, volume flow accuracy on liquid = ±0,30% when flow rate ≥ (zero stability / 0,002). When flow rate < (zero stability / 0,002), then volume accuracy on liquid = ±[1,5 × (zero stability / flow rate) × 100]% of rate.

Liquid flow performance *continued*

Typical accuracy, turndown, and pressure drop with transmitter with MVD technology

Pressure drop is dependent on process conditions. To determine accuracy, turndown, and pressure drop with your process variables, use Micro Motion's product selector, available at www.micromotion.com.

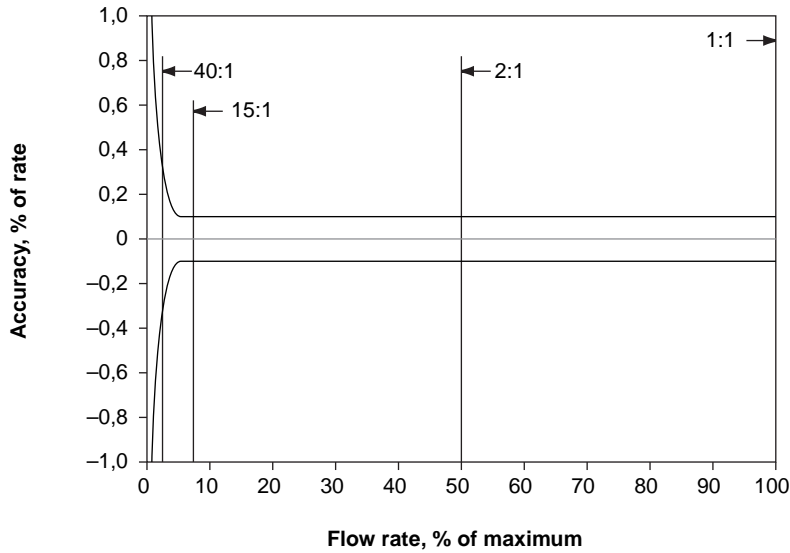

<i>Turndown from maximum flow rate</i>	40:1	15:1	2:1
Accuracy (\pm %)	0,26	0,10	0,10
Pressure drop (bar)	0,01	0,03	0,98

Density performance (liquid only)

Accuracy⁽¹⁾	$\pm 1,0 \text{ kg/m}^3$
Repeatability	$\pm 0,5 \text{ kg/m}^3$
Range	Up to 5000 kg/m^3

(1) Stated accuracy with calibration option 1 (see page 33). With other calibration options, accuracy is $\pm 2,0 \text{ kg/m}^3$ and repeatability is $\pm 1,0 \text{ kg/m}^3$.

Gas flow performance

When selecting sensors for gas applications, measurement accuracy is a function of fluid mass flow rate independent of operating temperature, pressure, or composition. However, pressure drop through the sensor is dependent upon operating temperature, pressure, and fluid composition. Therefore, when selecting a sensor for any particular gas application, it is highly recommended that each sensor be sized using Micro Motion's product selector, available at www.micromotion.com.

		Mass	Volume⁽¹⁾
		kg/h	Nm ³ /h
Typical flow rates that produce approximately 0,68 bar pressure drop on <i>air</i> at 20 °C and 6,8 bar			
	F025	116	90
	F050	357	276
	F100	1366	1055
	F200	3810	2940
	F300	14865	11512
Typical flow rates that produce approximately 3,4 bar pressure drop on <i>natural gas</i> (MW 16,675) at 20 °C and 34 bar			
	F025	445	598
	F050	1358	1825
	F100	5162	6936
	F200	14490	19470
	F300	50989	72247
Accuracy⁽²⁾	Transmitter with MVD technology	±0,50% of rate ⁽³⁾	
	All other transmitters ⁽⁴⁾	±0,70% of rate ±[(zero stability / flow rate) × 100]% of rate	
Repeatability	Transmitter with MVD technology	±0,25% of rate ⁽³⁾	
	All other transmitters ⁽⁴⁾	±0,35% of rate ±[(zero stability / flow rate) × 100]% of rate	
		kg/h	
Zero stability	F025	0,1765	
	F050	0,544	
	F100	2,177	
	F200	6,965	
	F300	21,76	

(1) Normal (Nm³/h) reference conditions are 1,013 bar-a and 0 °C.

(2) Stated flow accuracy includes the combined effects of repeatability, linearity, and hysteresis.

(3) When flow rate < (zero stability / 0,005), then accuracy = ±[(zero stability / flow rate) × 100]% of rate and repeatability = ±[½(zero stability / flow rate) × 100]% of rate.

(4) Model F300 sensors are compatible only with transmitters with MVD technology.

Gas flow performance *continued*

Typical accuracy and pressure drop with F100 with MVD technology

Air at 20 °C, static pressures as indicated on graph

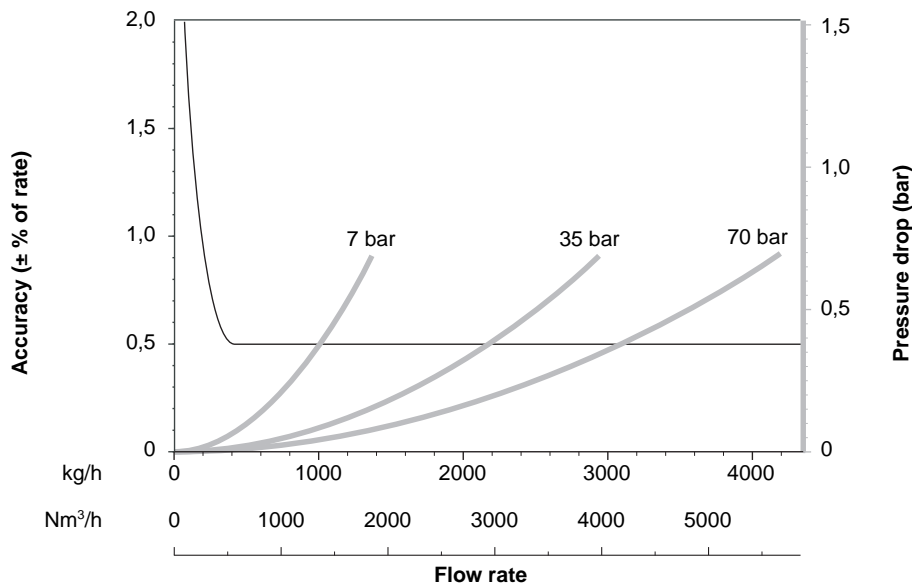

Natural gas (MW 16,675) at 20 °C, static pressures as indicated on graph

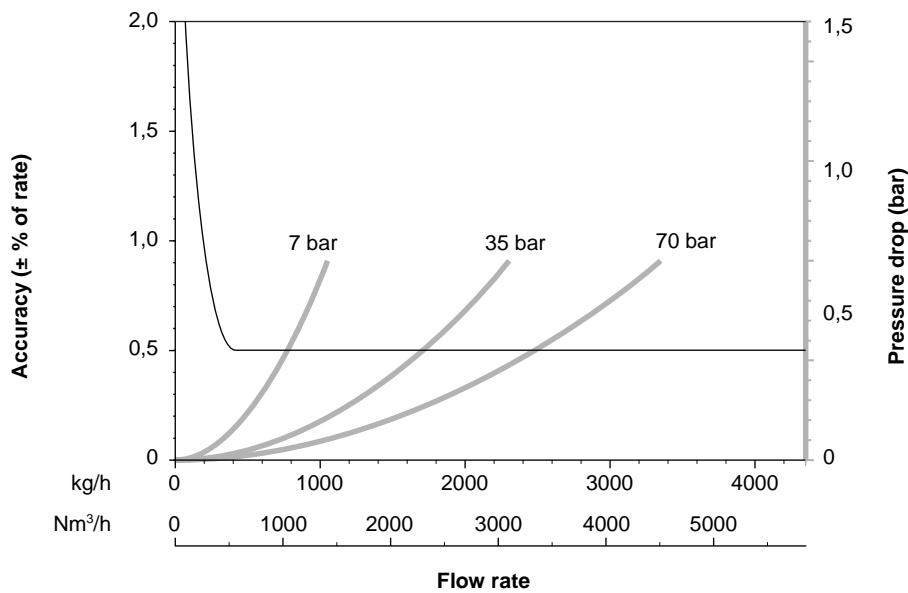

Standard or normal volumetric capability

Standard and normal volumes are "quasi mass" flow units for any fixed composition fluid. Standard and normal volumes do not vary with operating pressure, temperature, or density. With knowledge of density at standard or normal conditions (available from reference sources), a Micro Motion meter can be configured to output in standard or normal volume units without the need for pressure, temperature, or density compensation. Contact your local sales representative for more information.

Temperature specifications

Accuracy	All models	$\pm 1\text{ }^{\circ}\text{C} \pm 0,5\%$ of reading in $^{\circ}\text{C}$
Repeatability	All models	$\pm 0,2\text{ }^{\circ}\text{C}$

Temperature limits⁽¹⁾⁽²⁾⁽³⁾

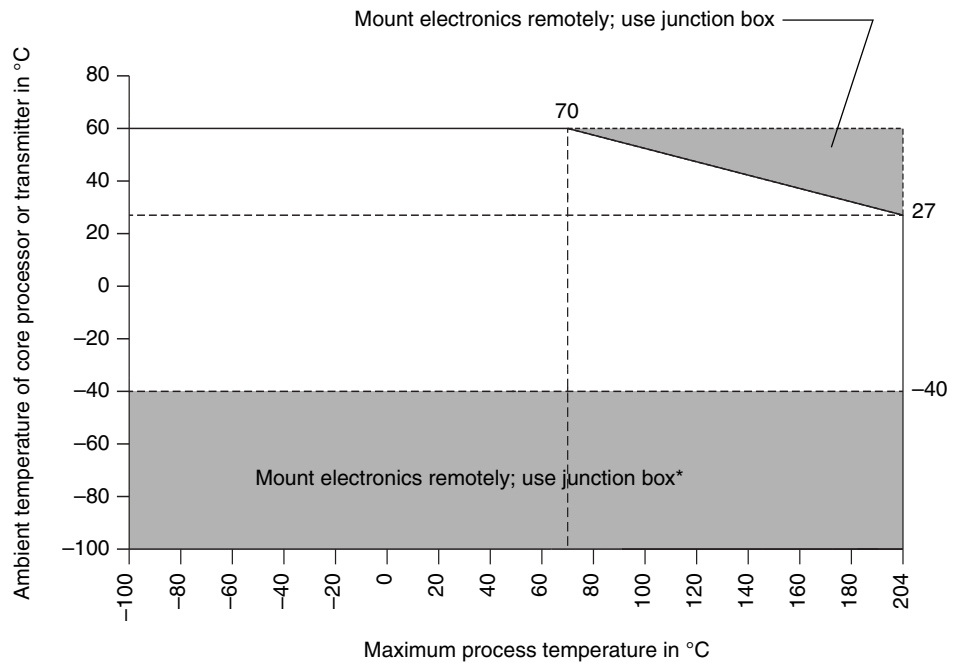

When ambient temperature is below $-40\text{ }^{\circ}\text{C}$, a core processor must be heated to bring its local ambient temperature to between $-40\text{ }^{\circ}\text{C}$ and $+60\text{ }^{\circ}\text{C}$. Long-term storage of electronics at ambient temperatures below $-40\text{ }^{\circ}\text{C}$ is not recommended.

High-temperature models

Ambient temperature:
 -40 to $+60\text{ }^{\circ}\text{C}$

Process temperature:
 -40 to $+350\text{ }^{\circ}\text{C}$

- (1) Temperature limits may be further restricted by hazardous area approvals. See pages 10–16.
- (2) The difference in temperature between the process fluid and the case cannot exceed $66\text{ }^{\circ}\text{C}$ for F300 sensors.
- (3) The extended mount option allows the sensor case to be insulated without covering the transmitter, core processor, or junction box, but does not affect temperature ratings.

Pressure ratings

		Material	bar
Flow tube rating⁽¹⁾	F025P	Stainless steel	158
	F050P	Stainless steel	345
	F300H	Nickel alloy	153
	All other models	Stainless steel	100
		Nickel alloy	148
PED compliance	Sensors comply with council directive 97/23/EC of 29 May 1997 on Pressure Equipment		
		ASME B31.3 secondary containment rating⁽¹⁾	Burst pressure used to determine ASME B31.3 secondary containment rating
		bar	bar
Housing rating⁽²⁾	F025	11,4	130
	F050	9,3	105
	F100	7,5	88,3
	F200	4,4	52,4
	F300	17,7	180

(1) Pressure rating at 25 °C, according to ASME B31.3. For operating temperatures above 148 °C, pressure needs to be derated as follows. Linear interpolation may be used between specified temperatures.

	Flow tubes		Housing
	316L sensors	Hastelloy [®] C-22 sensors	All sensors
up to 148 °C	None	None	None
at 204 °C	7,2% derating	None	5,4% derating
at 260 °C	13,8% derating	4,7% derating	11,4% derating
at 316 °C	19,2% derating	9,7% derating	16,2% derating
at 343 °C	21,0% derating	11,7% derating	18,0% derating
at 371 °C	22,8% derating	13,7% derating	19,2% derating

(2) Sensor housing is rated only when the secondary containment case option is purchased.

Vibration limits

Meets IEC 68.2.6, endurance sweep, 5 to 2000 Hz, 50 sweep cycles at 1,0 g

Environmental effects

Process temperature effect

Process temperature effect is defined as:

- For mass flow measurement, the worst-case zero offset due to process fluid temperature change away from the zeroing temperature.
- For density measurement, the maximum measurement offset due to process fluid temperature change away from the density calibration temperature.

Process temperature effect

	% of maximum flow rate per °C	density accuracy per °C ⁽¹⁾ (kg/m ³)
F025	±0,00175	±0,1
F050	±0,00175	±0,1
F100	±0,00175	±0,1
F200	±0,00175	±0,1
F300	±0,0040	±0,1

Pressure effect

Pressure effect is defined as the change in sensor flow and density sensitivity due to process pressure change away from the calibration pressure⁽²⁾. Pressure effect can be corrected.

Pressure effect on mass flow accuracy

	% of rate per psi	% of rate per bar
F025	None	None
F050	None	None
F100	None	None
F200	-0,001	-0,015
F300	-0,001	-0,015

Pressure effect on density accuracy

	g/cm ³ per psi	kg/m ³ per bar
F025	None	None
F050	None	None
F100	None	None
F200	-0,00003	-0,43
F300	-0,00003	-0,43

(1) For -100 °C and above.

(2) To determine factory calibration pressure, refer to the calibration document shipped with your sensor. If the data is unavailable, use 1,4 bar.

Hazardous area classifications

CSA and CSA C-US

Models F025, F050, F100, and F200 with junction box

Ambient temperature: +60 °C max.
Class I, Div. 1, Groups C and D
Class I, Div. 2, Groups A, B, C, and D
Class II, Div. 1, Groups E, F, and G

Models F025, F050, F100, and F200 with core processor or Model 1700/2700 transmitter

Ambient temperature: -40 to +60 °C
Class I, Div. 1, Groups C and D
Class I, Div. 2, Groups A, B, C, and D
Class II, Div. 1, Groups E, F, and G

Models F300S and F300H with junction box

Ambient temperature: +60 °C max.
Class I, Div. 1, Groups C and D
Class I, Div. 2, Groups A, B, C, and D
Class II, Div. 1, Groups E, F, and G

Models F300S and F300H with core processor or Model 1700/2700 transmitter

Ambient temperature: -40 to +60 °C
Class I, Div. 1, Groups C and D
Class I, Div. 2, Groups A, B, C, and D
Class II, Div. 1, Groups E, F, and G

All high-temperature models with junction box, core processor, or Model 1700/2700 transmitter

Ambient temperature: -40 to +60 °C
Class I, Div. 1, Groups C and D
Class I, Div. 2, Groups A, B, C, and D
Class II, Div. 1, Groups E, F, and G

Hazardous area classifications *continued*

NEPSI and IECEx⁽¹⁾

Models F025, F050, F100, F200 with core processor or
Model 1700/2700 transmitter Ex ib IIC T1–T5

Models F025, F050, F100 and F200 with junction box Ex ib IIC T1–T6

Model F300S and F300H with core processor or
Model 1700/2700 transmitter Ex ib IIB T1–T5

Models F300S and F300H with junction box Ex ib IIB T1–T6

UL

Models F025, F050, F100, and F200 with junction box
Ambient temperature: –20 to +40 °C
Class I, Div. 1, Groups C and D
Class I, Div. 2, Groups A, B, C, and D
Class II, Div. 1, Groups E, F, and G

(1) For both NEPSI and IECEx approvals, refer to the ATEX temperature graphs on the following pages for ambient and process temperature limits.

Hazardous area classifications *continued*

ATEX⁽¹⁾

(Certified per BVS 03 ATEX E 176 X)

All models with integral core processor or Model 1700/2700 transmitter

Transmitter with display:

CE 0575 $\text{\textcircled{Ex}}$ II 2 (1) G EEx ib IIB+H₂ T1-T5
II 2 D IP65 T °C

Core processor or transmitter without display:

CE 0575 $\text{\textcircled{Ex}}$ II 2 G EEx ib IIC T1-T5
II 2 D IP65 T °C

F025 and F050 with C.I.C. A2

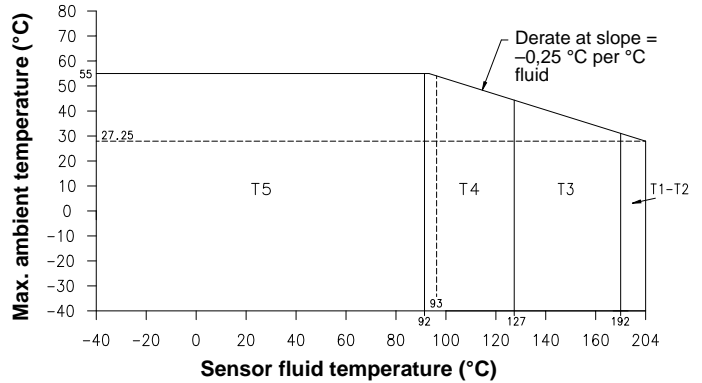

The maximum surface temperature for dust is as follows: T5:T 95°C, T4:T 130°C, T3:T 195°C, T2 to T1:T 207°C.

F100 with C.I.C. A2

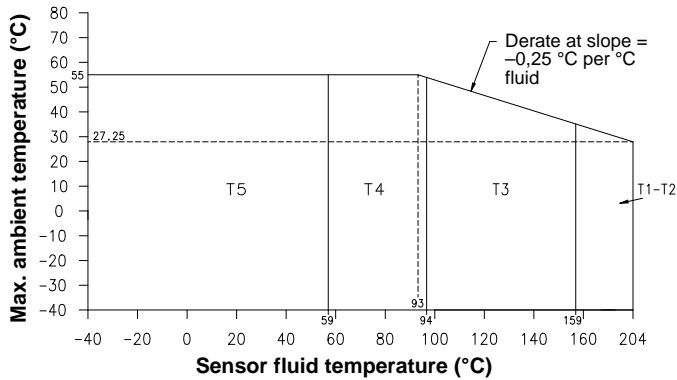

The maximum surface temperature for dust is as follows: T5:T 95°C, T4:T 130°C, T3:T 195°C, T2 to T1:T 240°C.

F200 with C.I.C. A1

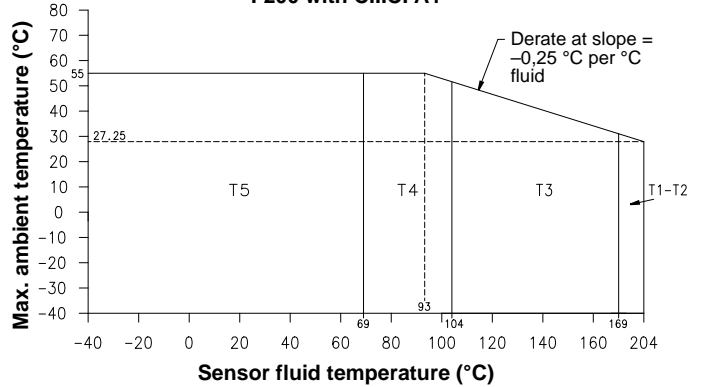

The maximum surface temperature for dust is as follows: T5:T 95°C, T4:T 130°C, T3:T 195°C, T2 to T1:T 230°C.

(1) ATEX "T" rating depends on the maximum temperature shown in the graphs above.

Hazardous area classifications *continued*

ATEX⁽¹⁾

(Certified per BVS 03 ATEX E 176 X)

Models F025, F050, F100, and F200 with junction box when connected to MVD transmitter

CE 0575 $\text{\textcircled{Ex}}$ II 2 G EEx ib IIC T1-T6
II 2 D IP65 T °C

F025 and F050 with C.I.C. A2

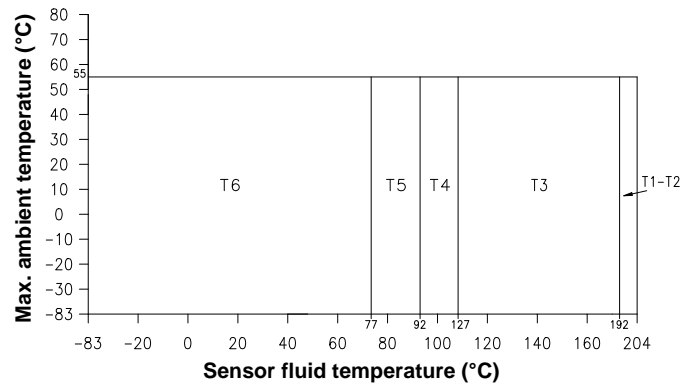

The maximum surface temperature for dust is as follows: T6:T 80°C, T5:T 95°C, T4:T 130°C, T3:T 195°C, T2 to T1:T 207°C
The minimum ambient and process fluid temperature allowed for dust is -40°C.

F100 with C.I.C. A2

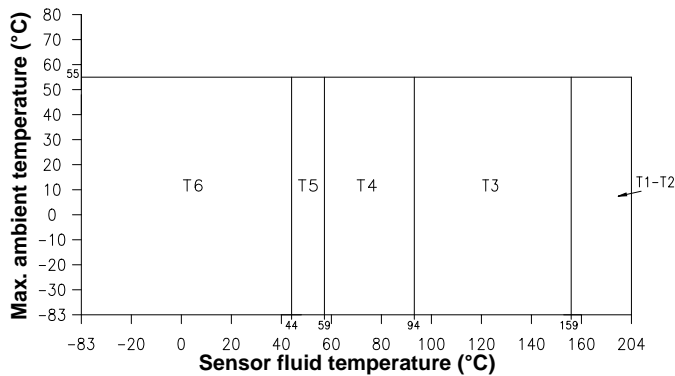

The maximum surface temperature for dust is as follows: T6:T 80°C, T5:T 95°C, T4:T 130°C, T3:T 195°C, T2 to T1:T 240°C
The minimum ambient and process fluid temperature allowed for dust is -40°C.

F200 with C.I.C. A1

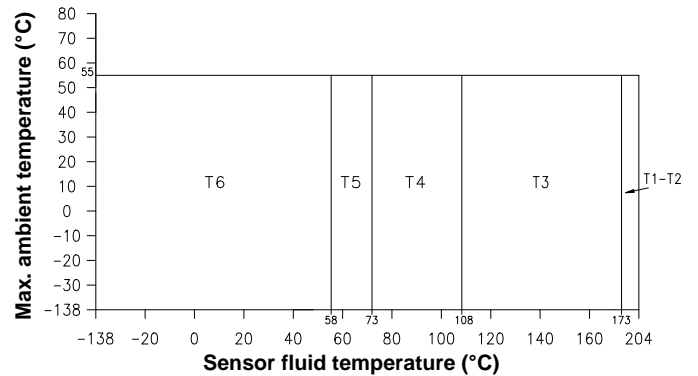

The maximum surface temperature for dust is as follows: T6:T 80°C, T5:T 95°C, T4:T 130°C, T3:T 195°C, T2 to T1:T 226°C
The minimum ambient and process fluid temperature allowed for dust is -40°C.

(1) ATEX "T" rating depends on the maximum temperature shown in the graphs above.

Hazardous area classifications *continued*

ATEX⁽¹⁾

(Certified per BVS 03 ATEX E 176 X)

Models F025, F050, F100, and F200 with junction box when connected to non-MVD transmitter

CE 0575  II 2 G EEx ib IIC T1-T6
II 2 D IP65 T °C

F025 and F050 with C.I.C. A2

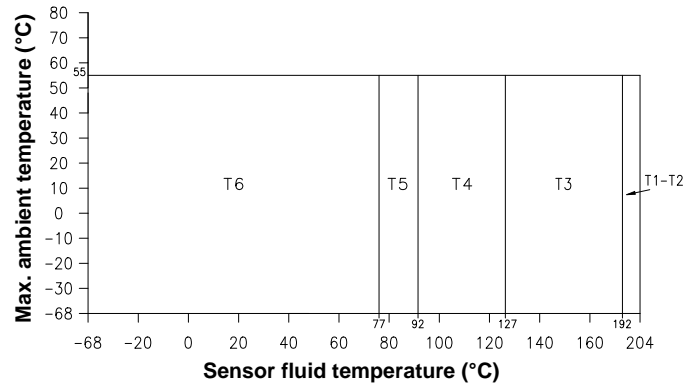

The maximum surface temperature for dust is as follows: T6:T 80°C, T5:T 95°C, T4:T 130°C, T3:T 195°C, T2 to T1:T 207°C
The minimum ambient and process fluid temperature allowed for dust is -40°C.

F100 with C.I.C. A2

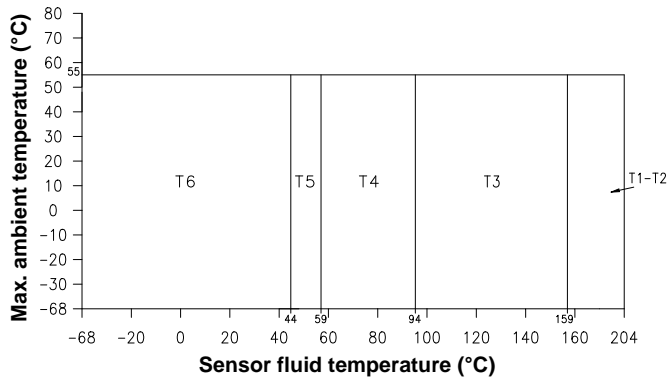

The maximum surface temperature for dust is as follows: T6:T 80°C, T5:T 95°C, T4:T 130°C, T3:T 195°C, T2 to T1:T 240°C
The minimum ambient and process fluid temperature allowed for dust is -40°C.

F200 with C.I.C. A1

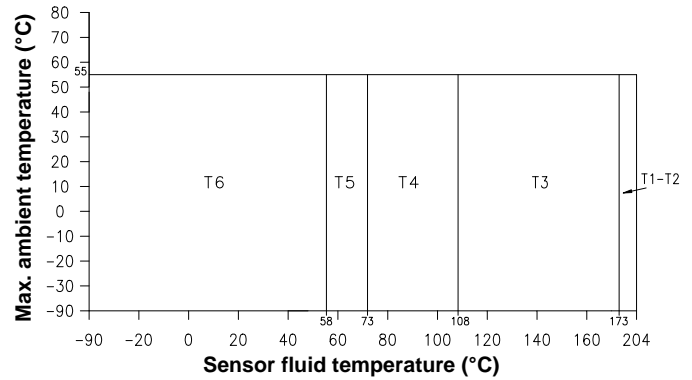

The maximum surface temperature for dust is as follows: T6:T 80°C, T5:T 95°C, T4:T 130°C, T3:T 195°C, T2 to T1:T 226°C
The minimum ambient and process fluid temperature allowed for dust is -40°C.

(1) ATEX "T" rating depends on the maximum temperature shown in the graphs above.

Hazardous area classifications *continued*

ATEX⁽¹⁾

(Certified per BVS 03 ATEX E 176 X)

Model F300 with integral core processor or Model 1700/2700 transmitter

CE 0575 Ex II 2 G EEx ib IIB T1-T5
II 2 D IP65 T °C

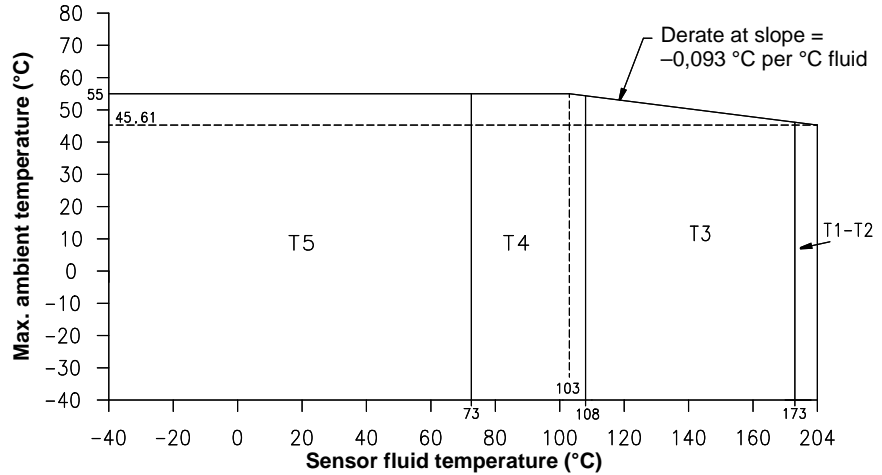

The maximum surface temperature for dust is as follows: T5:T 95°C, T4:T 130°C, T3:T 195°C, T2 to T1:T 226°C.

Model F300 with junction box connected to MVD transmitter

CE 0575 Ex II 2 G EEx ib IIB T1-T6
II 2 D IP65 T °C

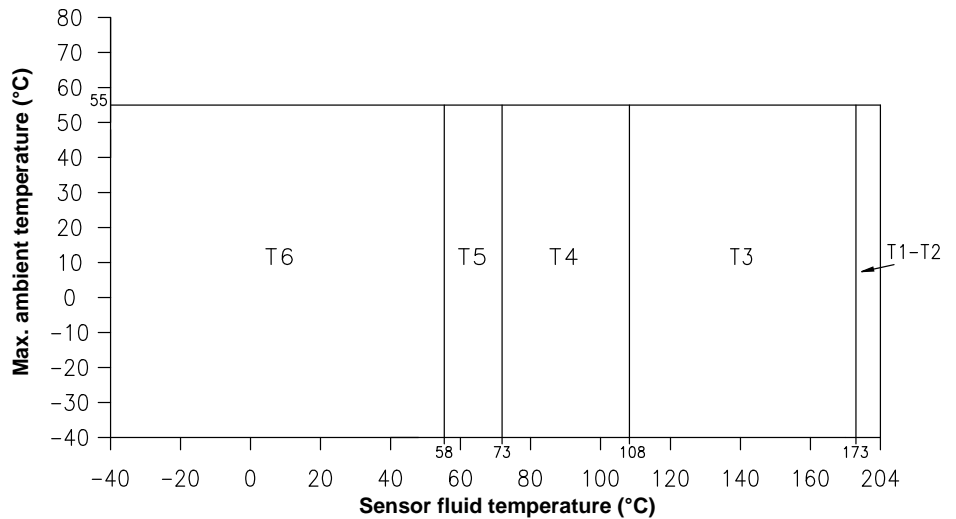

The maximum surface temperature for dust is as follows: T6:T 80°C, T5:T 95°C, T4:T 130°C, T3:T 195°C, T2-T1:T 226°C.

(1) ATEX "T" rating depends on the maximum temperature shown in the graphs above.

Hazardous area classifications *continued*

ATEX⁽¹⁾

(Certified per BVS 03 ATEX E 176 X)

Models F025(A or B), F050(A or B), and F100(A or B) with C.I.C. no marking or A3 with core processor or Model 1700/2700 transmitter

CE 0575 $\text{\textcircled{EX}}$ II 2 G EEx ib IIC T1–T5
II 2 D IP65 T °C

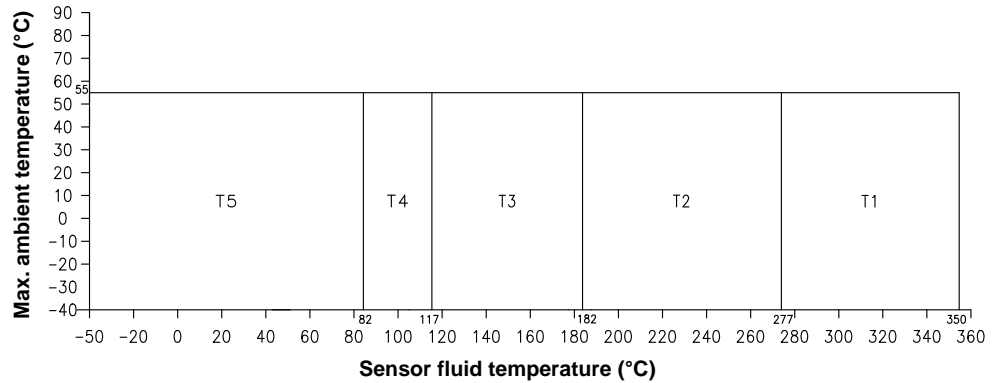

The maximum surface temperature for dust is as follows: T5:T 95°C, T4:T 130°C, T3:T 195°C, T2: T 290°C, T1:T 363°C. The minimum ambient and process fluid temperature allowed for dust is -40°C.

Models F025(A or B), F050(A or B), and F100(A or B) with C.I.C. no marking or A3 with junction box connected to MVD transmitter

CE 0575 $\text{\textcircled{EX}}$ II 2 G EEx ib IIC T1–T6
II 2 D IP65 T °C

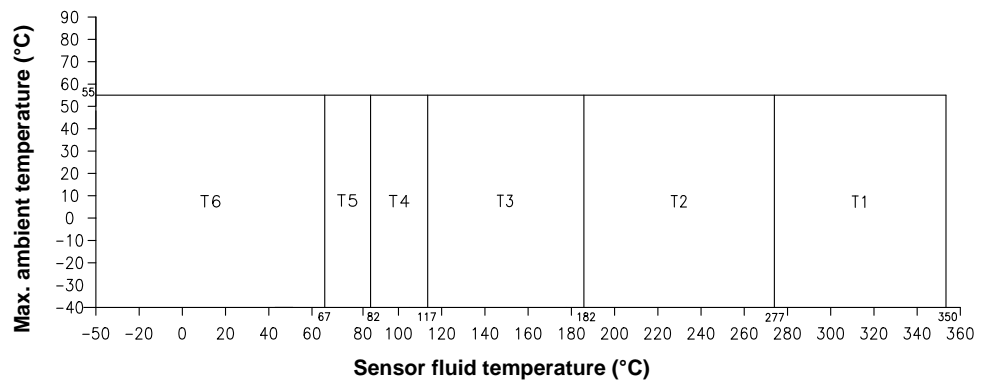

The maximum surface temperature for dust is as follows: T6:T 80°C, T5:T 95°C, T4:T 130°C, T3:T 195°C, T2:T 290°C, T1:T 363°C. The minimum ambient and process fluid temperature allowed for dust is -40°C.

(1) ATEX "T" rating depends on the maximum temperature shown in the graphs above.

Materials of construction

Wetted parts⁽¹⁾	All models	316L stainless steel or Hastelloy C-22 nickel alloy
Housing	Sensor	304L stainless steel
	Core processor	CF-3M stainless steel or polyurethane-painted aluminum; NEMA 4X (IP 65)
	Junction box	Stainless steel or polyurethane-painted aluminum; NEMA 4X (IP 65)

(1) General corrosion guidelines do not account for cyclical stress, and therefore should not be relied upon when choosing a wetted material for your Micro Motion meter. Please refer to the Micro Motion Corrosion Guide for material compatibility information.

Weight

Weights provided are the weight of the meter with ANSI CL150 weld neck raised face flanges. All weights are in kg.

	Core processor ⁽¹⁾	Extended core processor ⁽¹⁾	1700/2700	J-box	Extended J-box
F025S and F025P	5	6	8	5	5
F025H	6	6	8	6	6
F025A ⁽²⁾	8	—	10	8	—
F025B ⁽²⁾	9	—	11	9	—
F050S and F050P	6	6	9	5	6
F050H	6	7	9	6	7
F050A ⁽²⁾	8	—	11	8	—
F050B ⁽²⁾	9	—	11	9	—
F100S	10	11	13	10	10
F100H	10	11	12	10	11
F100A or F100B ⁽²⁾	12	—	15	12	—
F200S	20	20	23	20	20
F200H	25	26	27	25	26
F300S	71	72	74	71	71
F300H	73	73	76	73	73

(1) Weight stated for sensor with aluminum core processor. Add 2 kg for stainless steel core housing option (electronics interface codes A and B).

(2) For high-temperature models, the integral electronics are mounted at the end of a flexible conduit. The weights listed include the weight of the conduit.

Dimensions

Sensor with core processor

Dimensions in mm

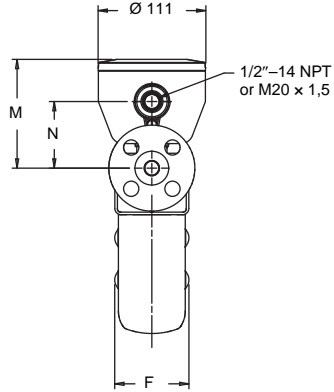
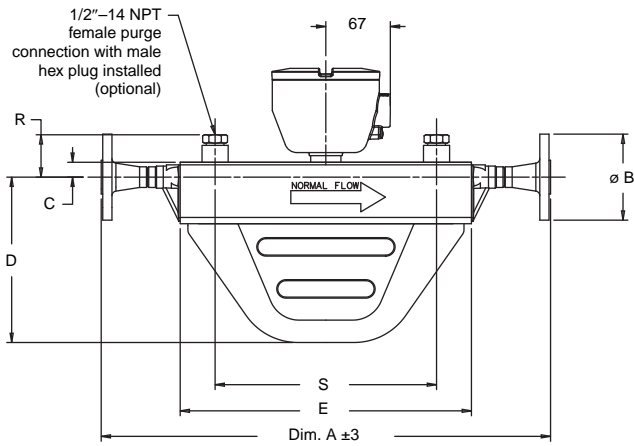

Extended mount option

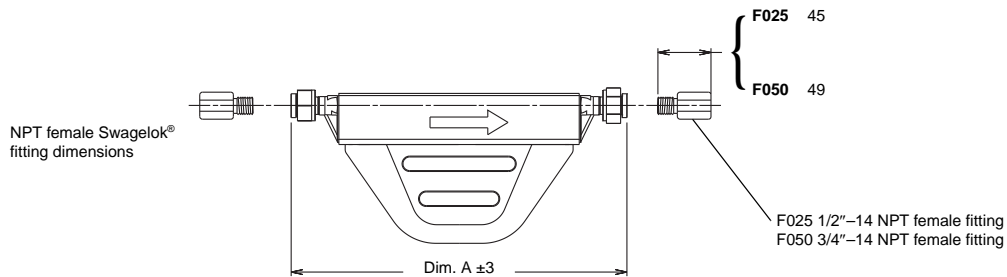
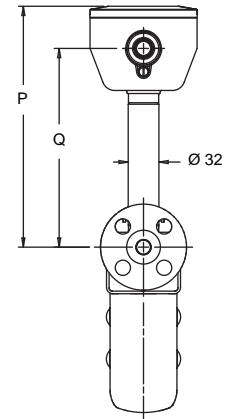

Dimensions⁽¹⁾ (mm)

Model	C	D	E	F	M	N	P	Q	R	S
F025	15	130	247	72	112	69	249	205	44	191
F050	15	171	301	74	112	69	249	205	44	229
F100	22	232	378	104	119	75	255	212	50	305
F200	44	319	454	144	141	98	278	234	73	356
F300	89	185	704	150	184	141	321	277	114	533

(1) For dimensions A and B, see process fitting tables on pages 24–29.

Dimensions *continued*

Sensor with integrally mounted Model 1700 or 2700 transmitter

Dimensions in mm

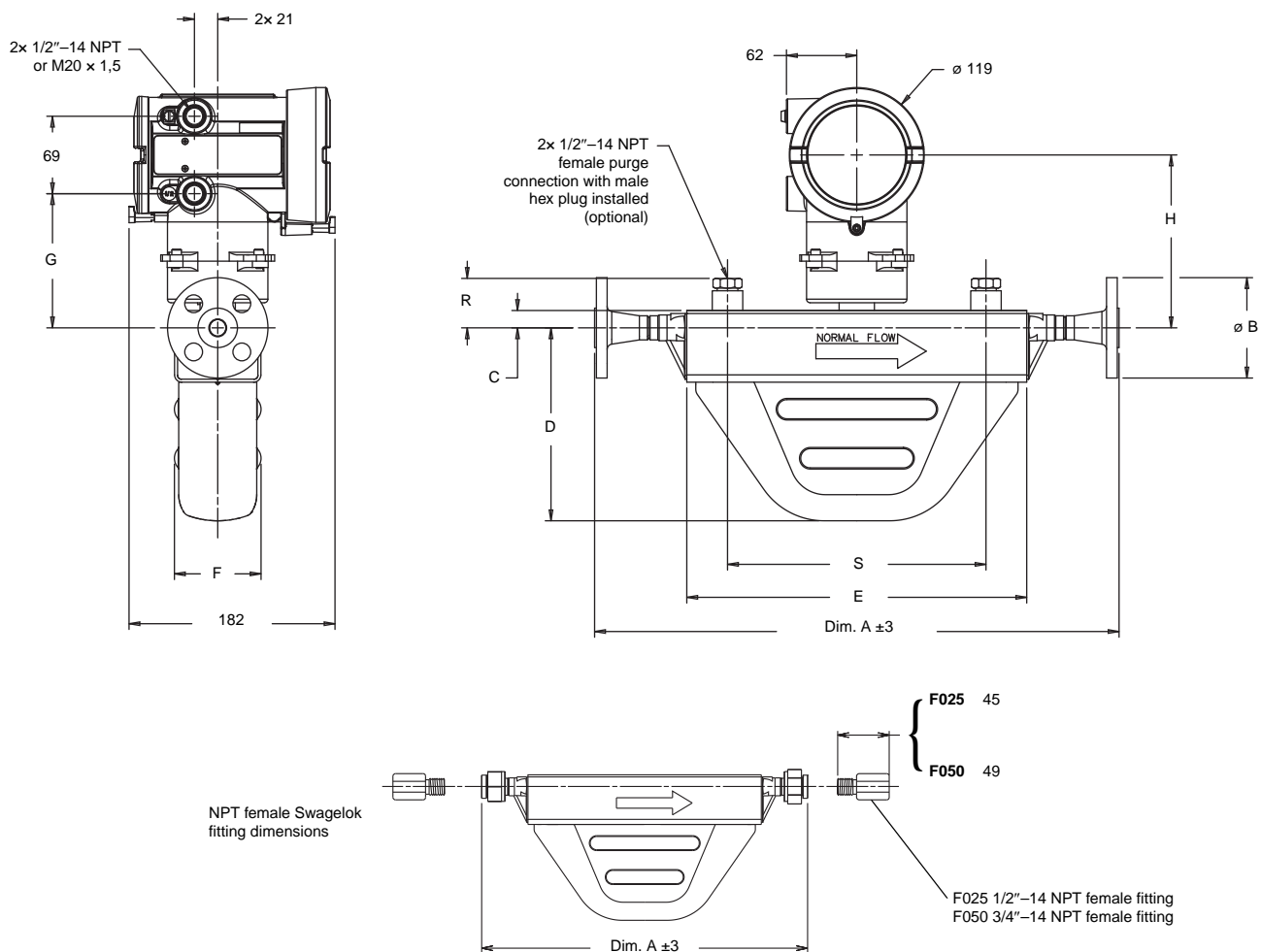

Model	Dimensions ⁽¹⁾ (mm)							
	C	D	E	F	G	H	R	S
F025	15	130	247	72	119	154	44	191
F050	15	171	301	74	119	154	44	229
F100	22	232	378	104	126	160	50	305
F200	44	319	454	144	148	182	73	356
F300	89	185	704	150	191	225	114	533

(1) For dimensions A and B, see process fitting tables on pages 24–29.

Dimensions *continued*

Sensor with junction box

Dimensions in mm

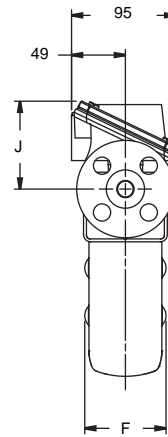
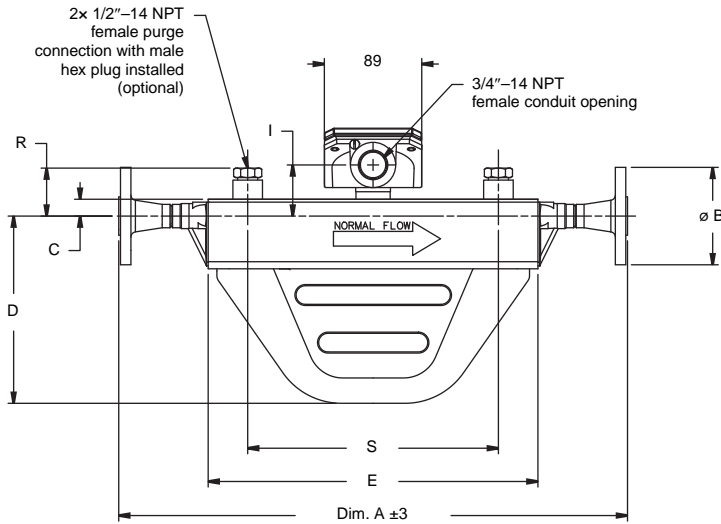

Extended mount option

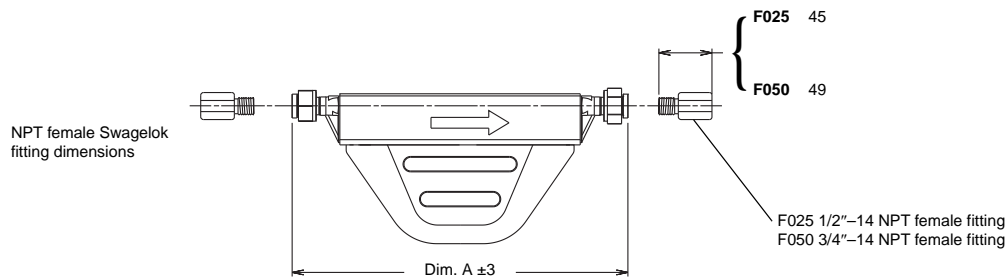
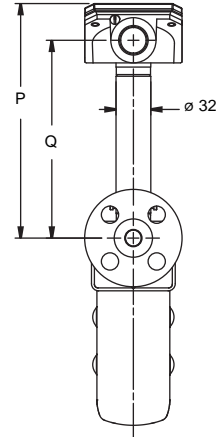

Dimensions⁽¹⁾ (mm)

Model	C	D	E	F	I	J	P	Q	R	S
F025	15	130	247	72	47	80	214	181	44	191
F050	15	171	301	74	47	80	214	181	44	229
F100	22	232	378	104	53	87	220	187	50	305
F200	44	319	454	144	76	109	243	209	73	356
F300	89	185	704	150	119	152	289	255	114	533

(1) For dimensions A and B, see process fitting tables on pages 24–29.

Dimensions *continued*

High-temperature Models F025(A and B), F050(A and B), and F100(A and B)

Dimensions in mm

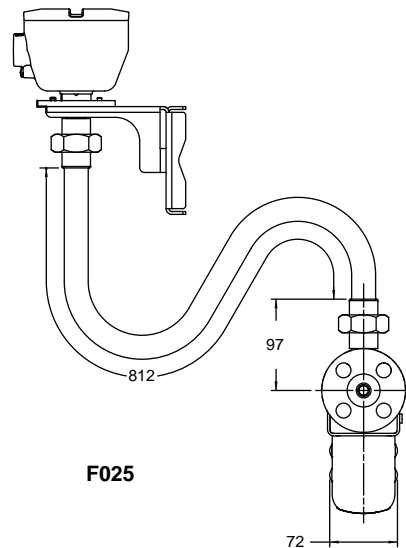

F025

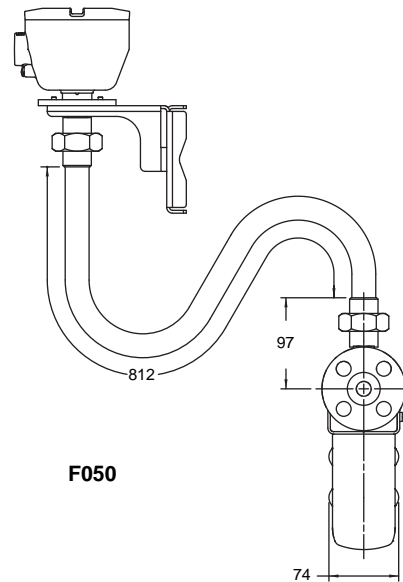

F050

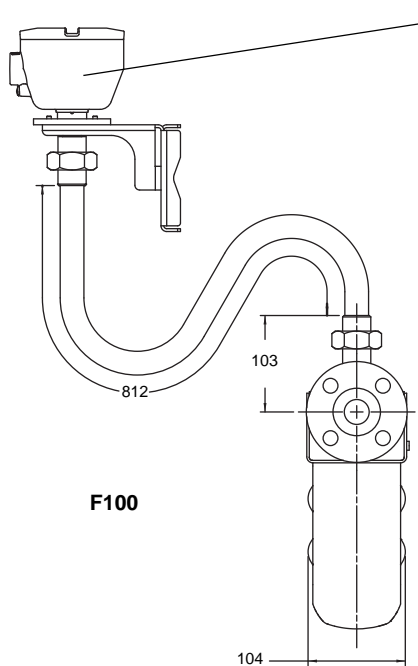

F100

Core processor, junction box, or Model 1700/2700 transmitter (core processor shown in all three views)

For remaining sensor dimensions, refer to pages 18–20.
For dimensions of electronics, refer to pages 22–23.

Dimensions *continued*

Core processor mounted on high-temperature sensor flexible conduit

Dimensions in mm

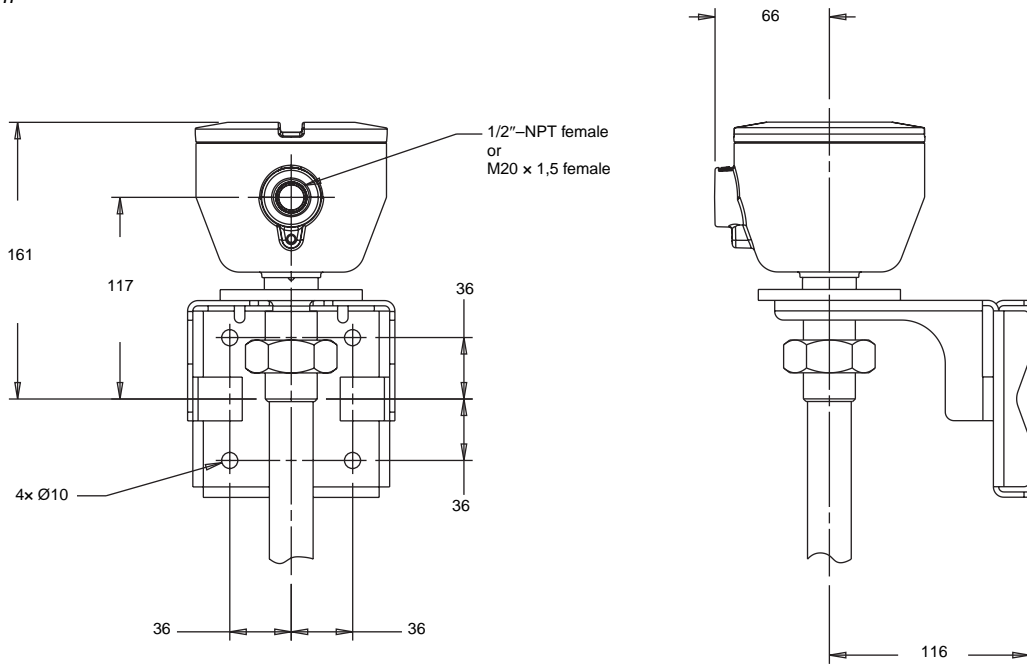

Junction box mounted on high-temperature sensor flexible conduit

Dimensions in mm

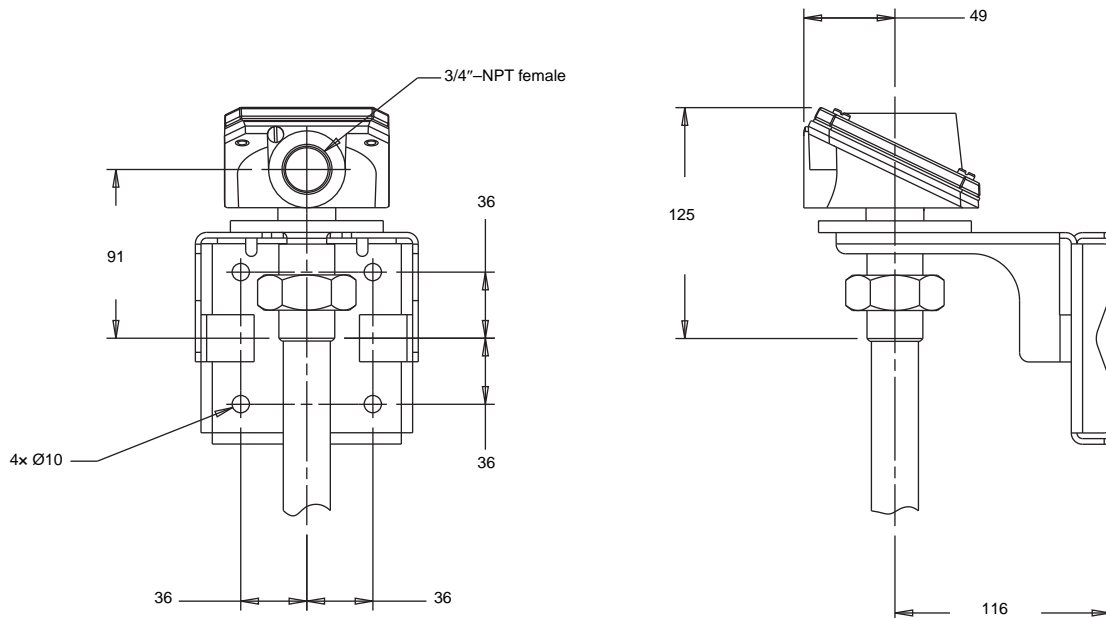

Dimensions *continued*

Model 1700/2700 transmitter mounted on high-temperature sensor flexible conduit

Dimensions in mm

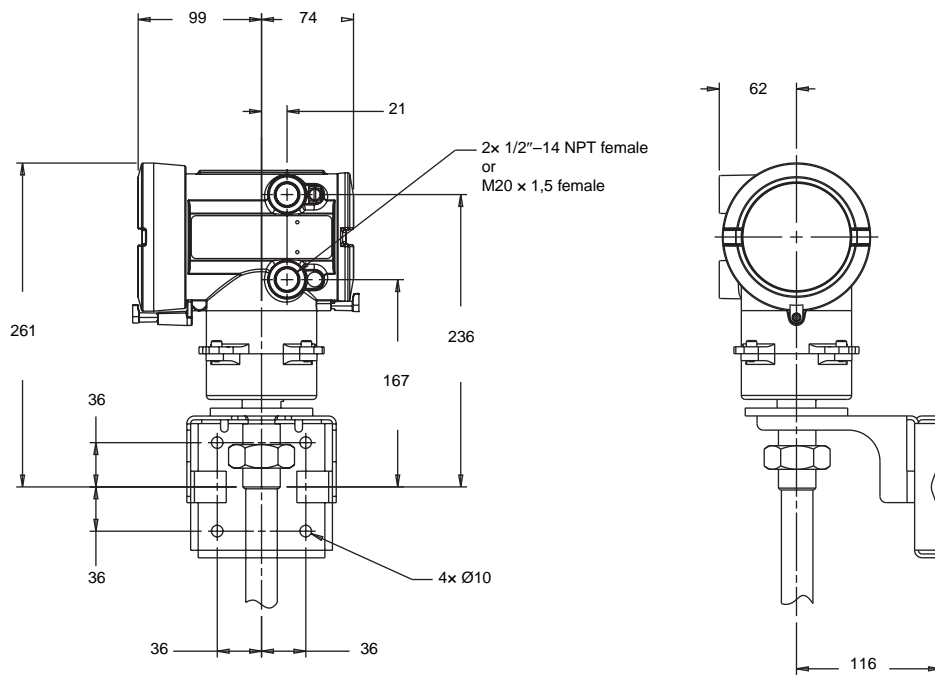

Fitting options

	Fitting code	Dim. A face-to-face (mm)	Dim. B outside diam. (mm)
F025S fitting options⁽¹⁾			
1/2-inch ANSI CL150 weld neck raised face flange	113	406	89
1/2-inch ANSI CL300 weld neck raised face flange	114	416	95
1/2-inch ANSI CL600 weld neck raised face flange	115	429	95
1/2-inch NPT female Swagelok size 8 VCO fitting	319	356 ⁽²⁾	not applicable
1/2-inch sanitary fitting (Tri-Clamp® compatible)	121	356	25
DN15 PN40 weld neck; DIN 2635 type C face	116	387	95
DN15 PN40 weld neck flange; EN 1092-1 Form B1	176	387	95
DN15 PN40 weld neck flange; EN 1092-1 Form D	310	387	95
DN25 PN40 weld neck flange; EN 1092-1 Form B1	172	400	115
DN25 PN40 weld neck flange; EN 1092-1 Form D	183	400	115
DN15 PN100/160 weld neck flange; DIN 2638 type E face	120	401	105
DN15 PN100/160 weld neck flange; EN 1092-1 Form B2	170	401	105
DN15 PN100 weld neck flange; EN 1092-1 Form D	178	401	105
15mm DIN 11851 hygienic coupling	222	353	Rd 34 x 1/8
F025H and F025B fitting options⁽¹⁾			
1/2-inch ANSI CL150 lap joint flange	520	406	89
1/2-inch ANSI CL300 lap joint flange	521	416	95
1/2-inch ANSI CL600 lap joint flange	517	416	95
DN15 PN40 lap joint flange; EN 1092-1 Form B1	524	387	95
F025P fitting options⁽¹⁾			
15mm DIN PN100/160 weld neck, DIN 2638, type E face	120	401	105
1/2-inch ANSI CL900 weld neck raised face flange	150	445	121
DN15 PN100/160 weld neck flange; EN 1092-1 Form B2	170	401	105
DN15 PN100 weld neck flange; EN 1092-1 Form D	178	401	105
DN25 PN100 weld neck flange; EN 1092-1 Form B2	180	427	150
1/2-inch NPT female Swagelok size 8 VCO fitting	319	356 ⁽²⁾	not applicable

(1) Fittings listed here are standard options. Other types of fittings are available. The face to face dimensions for any custom fittings ordered using a 998 or 999 fitting code are not represented in this table. It is necessary to confirm face to face dimensions of these fittings at time of ordering. Contact your local Micro Motion representative.

(2) Dimension specified in table does NOT include fitting length. For installation, modify Dim. A value to include fitting. See pages 18–23.

Fitting options *continued*

	Fitting code	Dim. A face-to-face (mm)	Dim B. outside diam. (mm)
F025A fitting options⁽¹⁾			
1/2-inch ANSI CL150 weld neck raised face flange	113	406	89
1/2-inch ANSI CL300 weld neck raised face flange	114	416	95
1/2-inch ANSI CL600 weld neck raised face flange	115	429	95
1/2-inch ANSI CL900 weld neck raised face flange	150	445	121
DN15 PN40 weld neck flange; EN 1092-1 Form B1	176	387	95
DN15 PN40 weld neck flange; EN 1092-1 Form D	310	387	95
DN15 PN100/160 weld neck flange; EN 1092-1 Form B2	170	401	105
DN15 PN100 weld neck flange; EN 1092-1 Form D	178	401	105
DN25 PN40 weld neck flange; EN 1092-1 Form B1	172	400	115
DN25 PN40 weld neck flange; EN 1092-1 Form D	183	400	115
F050S fitting options⁽¹⁾			
1/2-inch ANSI CL150 weld neck raised face flange	113	460	89
1/2-inch ANSI CL300 weld neck raised face flange	114	469	95
1/2-inch ANSI CL600 weld neck raised face flange	115	482	95
3/4-inch NPT female Swagelok size 12 VCO fitting	239	415 ⁽²⁾	not applicable
3/4-inch sanitary fitting (Tri-Clamp compatible)	322	403	25
DN15 PN40 weld neck flange; DIN 2635 type C face	116	441	95
DN15 PN40 weld neck flange; EN 1092-1 Form B1	176	441	95
DN15 PN40 weld neck flange; EN 1092-1 Form D	310	441	95
DN15 PN100/160 weld neck flange; DIN 2638 type E face	120	455	105
DN15 PN100/160 weld neck flange; EN 1092-1 Form B2	170	455	105
DN15 PN100 weld neck flange; EN 1092-1 Form D	178	455	105
DN25 PN40 weld neck flange; DIN 2635 type C face	131	444	115
DN25 PN40 weld neck flange; EN 1092-1 Form B1	172	444	115
DN25 PN40 weld neck flange; EN 1092-1 Form D	183	444	115
15mm DIN 11851 hygienic coupling	222	407	Rd 34 x 1/8

(1) Fittings listed here are standard options. Other types of fittings are available. The face to face dimensions for any custom fittings ordered using a 998 or 999 fitting code are not represented in this table. It is necessary to confirm face to face dimensions of these fittings at time of ordering. Contact your local Micro Motion representative.

(2) Dimension specified in table does NOT include fitting length. For installation, modify Dim. A value to include fitting. See pages 18–23.

Fitting options *continued*

	Fitting code	Dim. A face-to-face (mm)	Dim B. outside diam. (mm)
F050P fitting options⁽¹⁾			
1/2-inch ANSI CL150 weld neck raised face flange	113	460	89
1/2-inch ANSI CL300 weld neck raised face flange	114	469	95
1/2-inch ANSI CL600 weld neck raised face flange	115	482	95
1/2-inch ANSI CL900 weld neck raised face flange	150	499	121
DN15 PN40 weld neck flange; DIN 2635 type C face	116	441	95
DN15 PN100/160 weld neck flange; DIN 2638 type E face	120	455	105
DN25 PN40 weld neck flange; DIN 2635 type C face	131	444	115
DN15 PN100/160 weld neck flange; EN 1092-1 Form B2	170	456	105
DN15 PN100 weld neck flange; EN 1092-1 Form D	178	456	105
DN25 PN100 weld neck flange; EN 1092-1 Form B2	180	482	140
3/4-inch NPT female Swagelok size 12 VCO fitting	239	415 ⁽²⁾	not applicable
3/4-inch sanitary fitting (Tri-Clamp compatible)	322	403	25
F050H and F050B fitting options⁽¹⁾			
1/2-inch ANSI CL150 lap joint flange	520	460	89
1/2-inch ANSI CL300 lap joint flange	521	469	95
1/2-inch ANSI CL600 lap joint flange	517	469	95
DN15 PN40 lap joint flange; EN 1092-1 Form B1	524	441	95
F050A fitting options⁽¹⁾			
1/2-inch ANSI CL150 weld neck raised face flange	113	460	89
1/2-inch ANSI CL300 weld neck raised face flange	114	469	95
1/2-inch ANSI CL600 weld neck raised face flange	115	482	95
1/2-inch ANSI CL900 weld neck raised face flange	150	499	121
DN15 PN40 weld neck flange; EN 1092-1 Form B1	176	441	95
DN15 PN40 weld neck flange; EN 1092-1 Form D	310	441	95
DN15 PN100/160 weld neck flange; EN 1092-1 Form B2	170	456	105
DN15 PN100 weld neck flange; EN 1092-1 Form D	178	456	105
DN25 PN40 weld neck flange; EN 1092-1 Form B1	172	445	115
DN25 PN40 weld neck flange; EN 1092-1 Form D	183	445	115

(1) Fittings listed here are standard options. Other types of fittings are available. The face to face dimensions for any custom fittings ordered using a 998 or 999 fitting code are not represented in this table. It is necessary to confirm face to face dimensions of these fittings at time of ordering. Contact your local Micro Motion representative.

(2) Dimension specified in table does NOT include fitting length. For installation, modify Dim. A value to include fitting. See pages 18–23.

Fitting options *continued*

	Fitting code	Dim. A face-to-face (mm)	Dim B. outside diam. (mm)
F100S fitting options⁽¹⁾			
1-inch ANSI CL150 weld neck raised face flange	128	576	108
1-inch ANSI CL300 weld neck raised face flange	129	588	124
1-inch ANSI CL600 weld neck raised face flange	130	601	124
1-inch sanitary fitting (Tri-Clamp compatible)	138	540	50
2-inch ANSI CL150 weld neck raised face flange	209	585	152
DN25 PN40 weld neck flange; DIN 2635 type C face	131	544	115
DN25 PN100/160 weld neck flange; DIN 2638 type E face	137	580	140
25mm DIN 11851 hygienic coupling	230	522	Rd 52 x 1/6
DN25 PN40 weld neck flange; EN 1092-1 Form B1	179	545	115
DN25 PN40 weld neck flange; EN 1092-1 Form D	311	545	115
DN25 PN100 weld neck flange; EN 1092-1 Form B2	180	581	140
DN25 PN100 weld neck flange; EN 1092-1 Form D	181	581	140
F100H and F100B fitting options⁽¹⁾			
1-inch ANSI CL150 lap joint flange	530	576	108
1-inch ANSI CL300 lap joint flange	531	589	124
1-inch ANSI CL600 lap joint flange	535	589	124
DN25 PN40 lap joint flange; EN 1092-1 Form B1	534	545	115
F100A fitting options⁽¹⁾			
1-inch ANSI CL150 weld neck raised face flange	128	576	108
1-inch ANSI CL300 weld neck raised face flange	129	588	124
1-inch ANSI CL600 weld neck raised face flange	130	601	124
2-inch ANSI CL150 weld neck raised face flange	209	585	152
1-inch ANSI CL900 weld neck raised face flange	928	624	149
DN25 PN40 weld neck flange; EN 1092-1 Form B1	179	545	115
DN25 PN40 weld neck flange; EN 1092-1 Form D	311	545	115
DN25 PN100 weld neck flange; EN 1092-1 Form B2	180	581	140
DN25 PN100 weld neck flange; EN 1092-1 Form D	181	581	140

(1) Fittings listed here are standard options. Other types of fittings are available. The face to face dimensions for any custom fittings ordered using a 998 or 999 fitting code are not represented in this table. It is necessary to confirm face to face dimensions of these fittings at time of ordering. Contact your local Micro Motion representative.

Fitting options *continued*

	Fitting code	Dim. A face-to-face (mm)	Dim B. outside diam. (mm)
F200S fitting options⁽¹⁾			
1 1/2-inch ANSI CL150 weld neck raised face flange	341	629	127
1 1/2-inch ANSI CL300 weld neck raised face flange	342	642	155
1 1/2-inch ANSI CL600 weld neck raised face flange	343	654	155
2-inch ANSI CL150 weld neck raised face flange	418	632	152
2-inch ANSI CL300 weld neck raised face flange	419	645	165
2-inch ANSI CL600 weld neck raised face flange	420	664	165
1 1/2-inch sanitary fitting (Tri-Clamp compatible)	351	591	50
2-inch sanitary fitting (Tri-Clamp compatible)	352	581	64
DN40 PN40 weld neck flange; DIN 2635 type C face	381	598	150
DN50 PN40 weld neck flange; DIN 2635 type C face	382	600	165
DN50 PN100 weld neck flange; DIN 2637 type E face	378	641	195
DN40 PN40 weld neck flange; EN 1092-1 Form B1	368	594	150
DN40 PN40 weld neck flange; EN 1092-1 Form D	312	594	150
DN40 PN100 weld neck flange; EN 1092-1 Form B2	363	628	170
DN40 PN100 weld neck flange; EN 1092-1 Form D	366	628	170
DN50 PN40 weld neck flange; EN 1092-1 Form B1	369	600	165
DN50 PN40 weld neck flange; EN 1092-1 Form D	316	600	165
DN50 PN100 weld neck flange; EN 1092-1 Form B2	365	641	195
DN50 PN100 weld neck flange; EN 1092-1 Form D	367	641	195
40mm DIN 11851 hygienic coupling	353	589	Rd 65 × 1/6
50mm DIN 11851 hygienic coupling	354	591	Rd 78 × 1/6
F200H fitting options⁽¹⁾			
1 1/2-inch ANSI CL150 lap joint flange	540	629	127
1 1/2-inch ANSI CL300 lap joint flange	541	632	155
1 1/2-inch ANSI CL600 lap joint flange	519	632	155
DN40 PN40 lap joint flange; EN 1092-1 Form B1	548	598	150
DN50 PN40 lap joint flange; EN 1092-1 Form B1	549	600	165
2-inch ANSI CL150 lap joint flange	544	645	152
2-inch ANSI CL300 lap joint flange	545	654	165

(1) Fittings listed here are standard options. Other types of fittings are available. The face to face dimensions for any custom fittings ordered using a 998 or 999 fitting code are not represented in this table. It is necessary to confirm face to face dimensions of these fittings at time of ordering. Contact your local Micro Motion representative.

Fitting options *continued*

	Fitting code	Dim. A face-to-face (mm)	Dim B. outside diam. (mm)
F300S fitting options⁽¹⁾			
3-inch ANSI CL150 weld neck raised face flange	355	935	191
3-inch ANSI CL300 weld neck raised face flange	356	954	210
3-inch ANSI CL600 weld neck raised face flange	357	974	210
4-inch ANSI CL150 weld neck raised face flange	425	945	229
4-inch ANSI CL300 weld neck raised face flange	426	969	254
4-inch ANSI CL600 weld neck raised face flange	427	1012	273
DN80 PN40 weld neck flange; DIN 2635 type C face	391	915	200
DN100 PN40 weld neck flange; DIN 2635 type C face	392	926	235
DN80 PN40 weld neck flange; DIN 2635 type N grooved face	393	915	200
DN100 PN40 weld neck flange; DIN 2635 type N grooved face	394	926	235
DN80 PN100 weld neck flange; DIN 2637 type E face	395	958	230
DN100 PN100 weld neck flange; DIN 2637 type E face	396	983	265
DN80 PN100 weld neck flange; DIN 2637 type N grooved face	397	958	230
DN100 PN100 weld neck flange; DIN 2637 type N grooved face	398	983	265
DN80 PN40 weld neck flange; EN 1092-1 Form B1	371	912	200
DN80 PN40 weld neck flange; EN 1092-1 Form D	326	912	200
DN80 PN100 weld neck flange; EN 1092-1 Form B2	373	952	230
DN80 PN100 weld neck flange; EN 1092-1 Form D	375	952	230
DN100 PN40 weld neck flange; EN 1092-1 Form B1	372	926	235
DN100 PN40 weld neck flange; EN 1092-1 Form D	333	926	235
DN100 PN100 weld neck flange; EN 1092-1 Form B2	374	976	265
DN100 PN100 weld neck flange; EN 1092-1 Form D	359	976	265
3-inch sanitary fitting (Tri-Clamp compatible)	361	893	91
3-inch Victaulic® compatible fitting	410	935	89
F300H fitting options⁽¹⁾			
3-inch ANSI CL150 lap joint flange	550	934	191
3-inch ANSI CL300 lap joint flange	551	953	210
3-inch ANSI CL600 lap joint flange	539	953	210
DN80 PN40 lap joint flange; EN 1092-1 Form B1	554	914	200

(1) Fittings listed here are standard options. Other types of fittings are available. The face to face dimensions for any custom fittings ordered using a 998 or 999 fitting code are not represented in this table. It is necessary to confirm face to face dimensions of these fittings at time of ordering. Contact your local Micro Motion representative.

Ordering information

Model	Product description
Standard sensor models	
F025S	F-Series sensor; 6 mm; 316L stainless steel
F025H	F-Series sensor; 6 mm; Hastelloy C-22
F050S	F-Series sensor; 12 mm; 316L stainless steel
F050H	F-Series sensor; 12 mm; Hastelloy C-22
F100S	F-Series sensor; 25 mm; 316L stainless steel
F100H	F-Series sensor; 25 mm; Hastelloy C-22
F200S	F-Series sensor; 50 mm; 316L stainless steel
F200H	F-Series sensor; 50 mm; Hastelloy C-22
F300S	F-Series sensor; 75 mm; 316L stainless steel
F300H	F-Series sensor; 75 mm; Hastelloy C-22
High-pressure sensor models	
F025P	F-Series sensor; 6 mm; 316L stainless steel; 158 bar tube rating
F050P	F-Series sensor; 12 mm; 316L stainless steel; 345 bar tube rating
High-temperature sensor models	
F025A	F-Series sensor; 6 mm; high temperature; 316L stainless steel
F025B	F-Series sensor; 6 mm; high temperature; Hastelloy C-22
F050A	F-Series sensor; 12 mm; high temperature; 316L stainless steel
F050B	F-Series sensor; 12 mm; high temperature; Hastelloy C-22
F100A	F-Series sensor; 25 mm; high temperature; 316L stainless steel
F100B	F-Series sensor; 25 mm; high temperature; Hastelloy C-22
Code Process connection	
###	See fitting options on pages 24–29.
Code Case options	
C	Compact case
B ⁽¹⁾	Secondary containment with test report
P ⁽¹⁾	Secondary containment with test report and purge fittings (1/2-inch NPT female)
H ⁽¹⁾⁽²⁾	Hygienic case
Continued on next page	

(1) Not available with Model F050P.

(2) Not available with high-temperature sensors or nickel alloy sensors.

Ordering information *continued*

Code Electronics interface	
	All models except high-temperature models
Q	4-wire polyurethane-painted aluminum integral core processor for remotely mounted transmitter with MVD technology
A	4-wire stainless steel integral core processor for remotely mounted transmitter with MVD technology
V	4-wire polyurethane-painted aluminum integral core processor with extended mount for remotely mounted transmitter with MVD technology
B	4-wire stainless steel integral core processor with extended mount for remotely mounted transmitter with MVD technology
C	Integrally mounted Model 1700 or 2700 transmitter
R	9-wire polyurethane-painted aluminum junction box
H	9-wire polyurethane-painted aluminum junction box with extended mount
S	9-wire stainless steel junction box
T	9-wire stainless steel junction box with extended mount
	High-temperature models
Q	4-wire polyurethane-painted aluminum integral core processor for remotely mounted transmitter with MVD technology
A	4-wire stainless steel integral core processor for remotely mounted transmitter with MVD technology
C	Integrally mounted Model 1700 or 2700 transmitter
R ⁽¹⁾	9-wire polyurethane-painted aluminum junction box
S ⁽¹⁾	9-wire stainless steel junction box
Code Conduit connections	
	Electronics interface codes Q, A, V, and B
B	1/2-inch NPT — no gland
E	M20 — no gland
F	Brass/nickel cable gland (cable diameter 8,5 to 10 mm)
G	Stainless steel cable gland (cable diameter 8,5 to 10 mm)
	Electronics interface code C (integral transmitter)
A	No gland
	Electronics interface codes R, H, S, and T (9-wire junction box)
A	3/4-inch NPT — no gland
H	Brass/nickel cable gland
J	Stainless steel cable gland
Continued on next page	

(1) Only for connection to a transmitter with MVD technology.

Ordering information *continued*

Code	Approvals
M	Micro Motion standard (no approval)
N	Micro Motion standard / PED compliant (no approval)
C ⁽¹⁾	CSA (Canada only)
A	CSA C-US (U.S.A. and Canada)
U ⁽²⁾	UL
Z	ATEX — Equipment Category 2 (Zone 1) / PED compliant
I ⁽³⁾	IECEX Zone 1
P ⁽⁴⁾	NEPSI
Code	Language
A	Danish installation manual
C	Czech installation manual
D	Dutch installation manual
E	English installation manual
F	French installation manual
G	German installation manual
H	Finnish installation manual
I	Italian installation manual
M	Chinese installation manual
N	Norwegian installation manual
O	Polish installation manual
P	Portuguese installation manual
S	Spanish installation manual
W	Swedish installation manual
B	Hungarian CE requirements and English installation manual
K	Slovak CE requirements and English installation manual
T	Estonian CE requirements and English installation manual
U	Greek CE requirements and English installation manual
L	Latvian CE requirements and English installation manual
V	Lithuanian CE requirements and English installation manual
Y	Slovenian CE requirements and English installation manual
Continued on next page	

(1) Not available with high-temperature models or nickel-alloy models.

(2) Available only with electronics interface codes H and R. Not available with high-temperature models or nickel-alloy models.

(3) Available only with nickel-alloy models and high-temperature models.

(4) Available only with language option M (Chinese).

Ordering information *continued*

Code		Future option 1
Z		Reserved for future use
Code		Calibration options
Z		0,20% mass flow and 2,0 kg/m ³ density calibration
A ⁽¹⁾		0,15% mass flow and 2,0 kg/m ³ density calibration
1 ⁽¹⁾		0,10% mass flow and 1,0 kg/m ³ density calibration
Code		Measurement application software
Z		No measurement application software
Code		Factory options
Z		Standard product
X		ETO product
Typical model number: F050S 113 C Q E Z E Z A Z Z		

(1) Available only with MVD technology.

Micro Motion—The undisputed leader in flow and density measurement



World-leading Micro Motion measurement solutions from Emerson Process Management deliver what you need most:

Technology leadership

Micro Motion introduced the first reliable Coriolis meter in 1977. Since that time, our ongoing product development has enabled us to provide the highest performing measurement devices available.

Product breadth

From compact, drainable process control to high flow rate fiscal transfer—look no further than Micro Motion for the widest range of measurement solutions.

Unparalleled value

Benefit from expert phone, field, and application service and support made possible by more than 500000 meters installed worldwide and 30 years of flow and density measurement experience.

 www.micromotion.com

© 2007 Micro Motion, Inc. All rights reserved. Micro Motion is committed to continuous product improvement. As a result, all specifications are subject to change without notice. ELITE and ProLink are registered trademarks, and MVD and MVD Direct Connect are trademarks of Micro Motion, Inc., Boulder, Colorado. Micro Motion is a registered trade name of Micro Motion, Inc., Boulder, Colorado. The Micro Motion and Emerson logos are trademarks and service marks of Emerson Electric Co. All other trademarks are property of their respective owners.

Emerson Process Management Micro Motion Americas

Worldwide Headquarters
7070 Winchester Circle
Boulder, Colorado USA 80301
T: 800 522 6277
T: +1 (303) 527 5200
F: +1 (303) 530 8459
Mexico T: 52 55 5366 2622
Argentina T: 54 11 4837 7000
Brazil T: 55 15 3238 3677
Venezuela T: 58 26 1731 3394

Emerson Process Management Micro Motion Europe/Middle East

Central & Eastern Europe T: +41 41 7686 111
Dubai T: 971-4 8835235
France T: 0800 917 901
Germany T: 0800 182 5347
Italy T: 8008 77334
The Netherlands T: (31) 318 495 555
U.K. T: 0870 240 1978
Russia/CIS T: +7 495 981 9811

Emerson Process Management Micro Motion Asia Pacific

Australia T: (61) 3 9721 0200
China T: (86) 21 3895 4788
India T: (91) 22 5662 0566
Japan T: (81) 3 5769 6803
Korea T: (82) 2 3438 4600
Singapore T: (65) 6 777 8211

