

# FIELDVUE<sup>®</sup> DVC2000 Series Digital Valve Controllers

The DVC2000 Series digital valve controller (see figure 1) is simple to use, compact, and designed for easy mounting. It converts a 4–20 mA input signal into a pneumatic output signal, which feeds the control valve actuator. Instrument setup is performed with a push button and liquid crystal display (LCD) interface. This interface is protected from the environment within a sealed enclosure. The interface supports multiple languages, including German, French, Italian, Spanish, Chinese, Japanese and English.

The DVC2000 Series digital valve controller uses a two-stage positioner design. The pre-amplifier stage provides high static gain for responsiveness to small changes in the input signal. The power amplifier stage delivers the right volume of air to the actuator, combining superior dynamic performance with minimal steady-state air consumption.

The high performance, linkage-less feedback system eliminates physical contact between the valve stem and the positioner. There is no wear of parts so

cycle life is maximized. Additionally, the elimination of levers and linkages reduces the number of mounting parts and the mounting complexity. Positioner replacement and maintenance is simplified because the feedback parts stay connected to the actuator stem.

Designed to meet intrinsically safe and non-incendive requirements, this instrument delivers scalable functionality and high performance in a small package.

## Note

**Neither Emerson<sup>™</sup>, Emerson Process Management, Fisher<sup>®</sup>, nor any of their affiliated entities assumes responsibility for the selection, use and maintenance of any product. Responsibility for the selection, use and maintenance of any product remains with the purchaser and end-user.**



W8755

Figure 1. DVC2000 Series Digital Valve Controller



## Specifications

### Available Mountings

- Integral mounting to the Design GX Control Valve and Actuator System
- Sliding stem applications
- Quarter-turn rotary applications

DVC2000 Series positioners can also be mounted on other actuators that comply with IEC 60534-6-1, IEC 60534-6-2, VDI/VDE 3845 and NAMUR mounting standards.

### Input Signal

*Analog Input Signal:* 4–20 mA dc, nominal; can be configured for split range

*Minimum Voltage:* Voltage available at instrument terminals must be 8.5 volts for analog control, 9.0 volts for HART communication

*Maximum Voltage:* 30 volts dc

*Minimum Control Current:* 4.0 mA (below 3.5 mA may cause microprocessor restart)

*Overcurrent Protection:* Input circuitry limits current to prevent internal damage

*Reverse Polarity Protection:* No damage occurs from reversal of loop current

### Output Signal

Pneumatic signal as required by the actuator, up to 95% of supply pressure

**Minimum Span:** 0.5 bar (7 psig)

**Maximum Span:** 7 bar (101 psig)

**Action:** Single Acting, direct

### Supply Pressure<sup>(1)</sup>

**Recommended:** 0.5 bar (7 psig) greater than the maximum actuator requirements

**Maximum:** 7 bar (101 psig)

### Temperature Limits<sup>(1)</sup>

–40 to 85°C (–40 to 185°F). LCD may not be readable below –20°C (–4°F).

See the Hazardous Area Classification bulletins for specific ambient temperature limits of units approved for operation in hazardous areas.

### Air Consumption<sup>(2)</sup>

*Supply pressure:*

*At 1.5 bar (22 psig)<sup>(3)</sup>:* 0.06 normal m<sup>3</sup>/h (2.3 scfh)

*At 4 bar (58 psig)<sup>(4)</sup>:* 0.12 normal m<sup>3</sup>/h (4.4 scfh)

### Air Capacity<sup>(2)</sup>

*Supply pressure:*

*At 1.5 bar (22 psig)<sup>(3)</sup>:* 4.48 normal m<sup>3</sup>/h (167 scfh)

*At 4 bar (58 psig)<sup>(4)</sup>:* 9.06 normal m<sup>3</sup>/h (338 scfh)

### Independent Linearity

±0.5% of output span

### Electromagnetic Interference (EMI)

Tested per IEC 61326-1 (Edition 1.1). Complies with European EMC Directive. Meets emission limits for class A equipment (industrial locations) and class B equipment (domestic locations). Meets immunity requirements for industrial locations (Table A.1 in the IEC specification document). Immunity performance is shown in table 1.

### Electrical Classification

#### Hazardous Area:



Intrinsically Safe and Non-incendive



Intrinsically Safe and Non-incendive

ATEX Intrinsically Safe

IECEx Intrinsically Safe

Refer to tables 2 and 3 and Hazardous Area Classification Bulletins 9.2:001 series and 9.2:002 for additional information.

**Electrical Housing:** Designed to meet IP66<sup>(5)</sup>

### Connections

#### Standard

*Supply and Output Pressure:* G1/4 female

*Electrical:* M20 female

#### Optional

*Supply and Output Pressure:* 1/4-inch NPT female

*Electrical:* 1/2-inch NPT female

**Specifications (continued)**

<p><b>Materials of Construction</b></p> <p><i>Housing and Cover:</i> ASTM B85 A03600 low copper aluminum alloy <i>Elastomers:</i> nitrile, fluorosilicone</p> <p><b>Stem Travel</b></p> <p><b>Minimum:</b> 8 mm (0.3125 inch) <b>Maximum:</b> 50 mm (2-inches)</p> <p><b>Shaft Rotation</b></p> <p><b>Minimum:</b> 45° <b>Maximum:</b> 90°</p> <p><b>Mounting</b></p> <p>Designed for direct actuator mounting. For weatherproof housing capability, the vent must be positioned at the lowest point of the instrument.</p> <p><b>Weight</b></p> <p>1.5 kg (3.3 lbs)</p>	<p><b>Dimensions</b></p> <p>Refer to figure 4</p> <p><b>Options</b></p> <ul style="list-style-type: none"> <li>■ <i>Airset:</i> Type 67CFR with filter</li> <li>■ <i>Language:</i> German, French, Italian, Spanish, Chinese, Japanese, English</li> <li>■ Pipe-away vent</li> <li>■ <i>Limit Switches:</i> Two isolated switches, configurable throughout calibrated travel range <i>Supply Voltage:</i> 5–30 V dc <i>OFF State:</i> 0.5 to 1.0 mA <i>ON State:</i> 3.5 to 4.5 mA (above 5 V) <i>Reference Accuracy:</i> 2% of travel span<sup>(6)</sup></li> <li>■ <i>Transmitter:</i> 4–20 mA output, isolated <i>Supply Voltage:</i> 8–30 V dc <i>Fault Indication:</i> offrange high or low <i>Reference Accuracy:</i> 1% of travel span<sup>(6)</sup></li> </ul>
--	--

1. The pressure/temperature limits in this document and any applicable standard or code limitation should not be exceeded. Note: Temperature limits vary based on hazardous area approval.  
 2. Normal m<sup>3</sup>/hour – Normal cubic meters per hour at 0°C and 1.01325 bar, absolute. Scfh – Standard cubic feet per hour at 60°F and 14.7 psia.  
 3. Low pressure relay: 0 to 3.4 bar (0 to 50 psig).  
 4. High pressure relay: 3.5 to 7.0 bar (51 to 102 psig).  
 5. Approval pending. Contact your Fisher sales office for information on pending approvals.  
 6. Typical values when calibrated at temperature.

Table 1. Immunity Performance

Port	Phenomenon	Basic Standard	Performance Criteria <sup>(1)</sup>
Enclosure	Electrostatic discharge (ESD)	IEC 61000-4-2	B
	Radiated EM field	IEC 61000-4-3	A
	Rated power frequency magnetic field	IEC 61000-4-8	A
I/O signal/control	Burst (fast transients)	IEC 61000-4-4	A
	Surge	IEC 61000-4-5	B
	Conducted RF	IEC 61000-4-6	A

Performance criteria is +/- 1% effect.  
 1. A = No degradation during testing. B = Temporary degradation during testing, but is self-recovering.

**Features**

- **Simplicity**—The DVC2000 Series is easy to use. If you are mounting the instrument for the first time, the linkage-less feedback system is easy to install. Once a magnet array is assembled to the valve stem, positioner replacement is simple since there are no physically connected parts.

At its very basic functionality, the DVC2000 Series digital valve controller has a local user interface that will allow you to configure, calibrate, and tune the instrument. If the I/O Options Package is installed, you can calibrate the 4–20 mA transmitter and

configure the limit switch action. Running the Quick Setup routine calibrates and tunes the instrument specifically for that actuator.

The full text display in the local interface is easy to navigate, in part due to the selection of languages. Each unit can be configured to display English, German, French, Italian, Spanish, Japanese or Chinese.

- **Reliability**—The DVC2000 is based on the field proven FIELDVUE<sup>®</sup> technology. Fisher’s years of control experience has brought this product line to a high level of reliability and dependability.

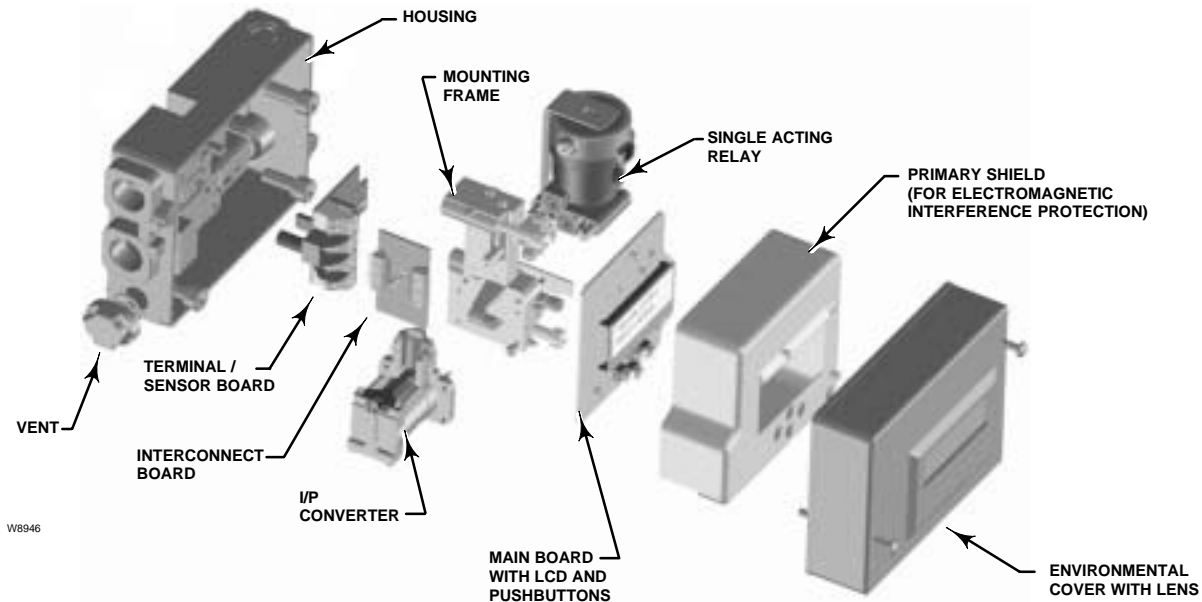

Figure 2. DVC2000 Series Digital Valve Controller Assembly (Exploded View)

- Performance**—The two-stage positioner design provides a mechanical platform that enables responsiveness to small input changes and tighter process control. The digital tuning algorithm allows optimal response to get the valve to its desired position quickly.

- Diagnostics**—*Local User Interface:* DVC2000 Series instruments come standard with a liquid crystal display. Predefined instrument and valve diagnostics are built into the firmware to alert you if there are any problems with the mounting, electronics, hardware, or valve performance.

*Handheld Field Communicator:* DVC2000 Series instruments are packed with user-configurable alerts and alarms. These flags provide notification of current status and potential valve and instrument problems through alerts such as travel deviation, travel limit, cycle count, and travel accumulation.

*AMS ValveLink® Software:* With AMS ValveLink Software, tests can be performed to identify problems with the entire control valve assembly. Using the valve stem travel feedback, actuator pressure sensor, and other sensors on the instrument, the health of the control valve can be evaluated while the valve is still in service and fully

operational. This helps to pinpoint problems without disrupting the process – before the equipment fails.

- I/O Options Package**— The DVC2000 Series is available with an I/O Options Package which includes two (2) integral limit switches and a stem position transmitter. The limit switches are configurable for open and closed valve indication at any point throughout the calibrated travel range. The position transmitter provides a 4–20 mA signal for valve position feedback verification. As an integral component to the instrument, this option module avoids the need for difficult-to-mount external switches and transmitters.

## Integration

### Traditional 4–20 mA Systems

Because the DVC2000 Series instrument operates with a 4–20 mA control signal, it directly replaces older analog instruments. Microprocessor based electronics provide improved control performance along with repeatable and reliable configuration and calibration.

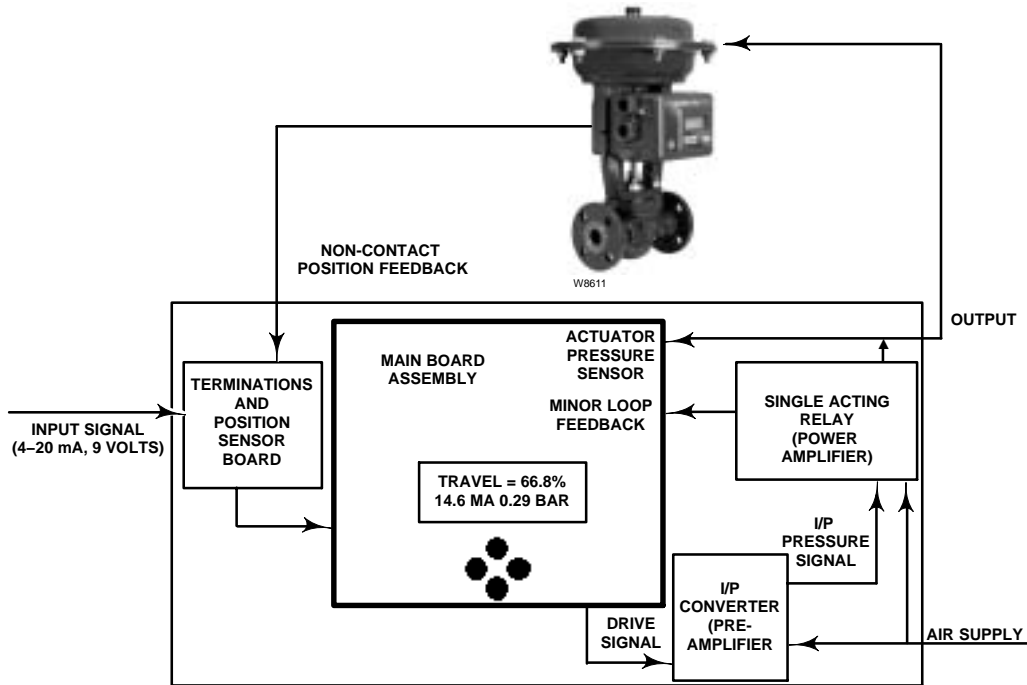

Figure 3. DVC2000 Series Digital Valve Controller Block Diagram

**Modbus with AMS ValveLink® Software and HART® Multiplexers**

HART® communication allows you to extract more value from the DVC2000 Series instrument beyond its inherent improved performance. When integrated into a multiplexer network and using AMS ValveLink Software, the device and valve information is real-time. From the safety of a control room, multiple instruments can be monitored for alerts and alarms.

Additionally, tasks such as configuration, calibration, and diagnostic testing do not require special trips to the field. AMS ValveLink Software can communicate via Modbus to the distributed control system (DCS) to provide critical information such as valve travel alerts and alarms.

**Integrated Control System**

A control system with HART communication capabilities has the ability to directly gather information from DVC2000 Series digital valve controllers. Information such as valve travel, alerts and alarms can be seamlessly accessed to provide a view into the field device from the safety of the control room.

**Principle of Operation**

DVC2000 Series instruments (figures 2 and 3) receive a 4–20 mA set point and position the valve by increasing or decreasing the air output to an actuator.

- The **input signal** provides electrical power and the set point simultaneously. The 4–20 mA signal is routed into **the terminals** through a twisted pair of wires.
- The unit's **mainboard** contains a microprocessor that continuously runs a digital control algorithm. This algorithm produces a “drive signal” to the I/P converter.
- **The I/P converter** assembly (or pre-amplifier) is connected to supply pressure and converts the electronic “drive signal” into a pneumatic “pressure signal.” This pressure signal is the input to the pneumatic relay assembly.
- **The relay** (or power amplifier) is also connected to supply pressure and amplifies the small pressure signal from the I/P converter into a larger pressure output signal used by the actuator. The change in relay output pressure to the actuator causes the valve to move.

There are two relay options. The low pressure relay operates with actuators that require less than 3.5 bar (50 psi) of supply air. The high pressure relay operates with actuators that require 3.5 to 7.0 bar (50 to 100 psi) of supply air.

- Valve position is sensed through the linkage-less feedback system. The travel sensor is electrically connected to the printed wiring board to provide a travel feedback signal used in the control algorithm. The valve continues to move until the correct position is attained.

## Installation

The DVC2000 Series is designed for mounting on any single acting pneumatic actuator up to 50 mm (2 inches) of travel. Double acting operation can be achieved with the addition of an externally mounted pneumatic reversing relay. The envelope and travel feedback system conforms to VDI/VDE 3845, IEC 60534-6-1, and IEC 60534-6-2 standards.

Furthermore, the DVC2000 Series instrument can be integrally mounted to the Design GX actuator, avoiding the need for complicated mounting brackets. The positioner mounts directly to an interface pad on the actuator yoke leg with a secure 3-point mounting. Internal passages inside the actuator yoke legs route the pneumatic output of the digital valve controller to the actuator casing, eliminating the need for external tubing (only for the air-to-open configuration).

Electrical connections are made on the termination strip, which uses cage clamp style wiring connectors. The electrical wiring entry point is available with either M20 or 1/2-inch NPT female connections. Pressure connections are available with either G1/4 or 1/4-inch NPT female connections.

## Ordering Information

Refer to the Specifications section. Carefully review each specification and indicate your choice whenever a selection is to be made.

When ordering, specify:

1. Actuator type and size
2. Maximum actuator travel or rotation
3. Minimum actuator operating pressure
4. Hazardous area certification requirements
5. Options
  - a. G1/4 pneumatic and M20 conduit connections or 1/4-inch NPT pneumatic and 1/2-inch NPT conduit connections
  - b. Language (German, French, Italian, Spanish, Chinese, Japanese, English)
  - c. Supply pressure regulator
  - d. Valve diagnostic level (online performance testing, offline advanced testing, basic alerts/alarms)
  - e. I/O Options Package (includes position transmitter and two (2) limit switches)
  - f. Pipe-away vent connector
  - g. HART filter

### Note

**Neither Emerson, Emerson Process Management, Fisher, nor any of their affiliated entities assumes responsibility for the selection, use and maintenance of any product. Responsibility for the selection, use and maintenance of any product remains with the purchaser and end-user.**

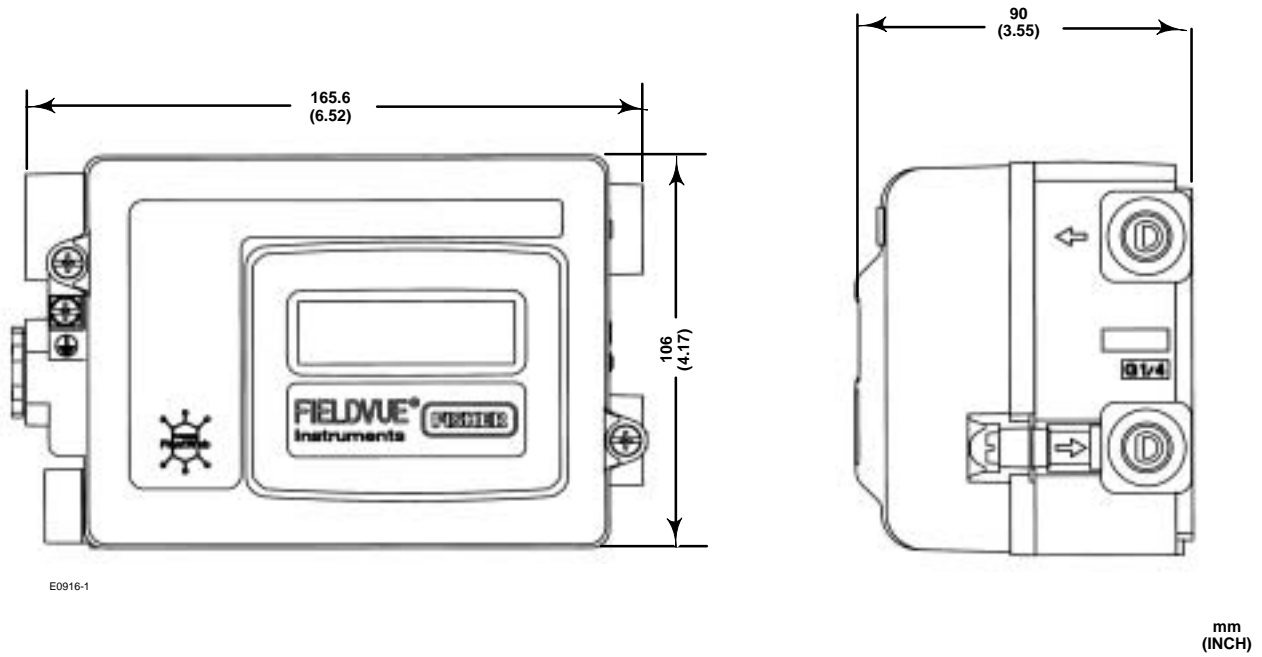

Figure 4. Dimensions for Type DVC2000 Digital Valve Controller

Table 2. Hazardous Area Classifications for North America

CERTIFICATION BODY	CERTIFICATION OBTAINED	ENTITY RATINGS	TEMPERATURE CODE	ENCLOSURE RATING
CSA	(Intrinsic Safety) Zone •Ex ia IIC T4/T5 Class/Division •Class I Division 1 GP A,B,C,D per drawing GE12444	(Main Circuit) $V_{max} = 30 \text{ Vdc}$ $I_{max} = 130 \text{ mA}$ $P_i = 1.0 \text{ W}$ $C_i = 5 \text{ nF}$ $L_i = 0.55 \text{ mH}$	T4( $T_{amb} < 80\text{C}$ ) T5( $T_{amb} < 40\text{C}$ )	---
	Class I Division 2 GP A,B,C,D	---	T5( $T_{amb} < 80\text{C}$ )	---
FM	(Intrinsic Safety) Class/Division •Class I Division 1 GP A,B,C,D per drawing GE10683	(Main Circuit) $V_{max} = 30 \text{ Vdc}$ $I_{max} = 130 \text{ mA}$ $P_i = 1.0 \text{ W}$ $C_i = 5 \text{ nF}$ $L_i = 0.55 \text{ mH}$	T4( $T_{amb} < 80\text{C}$ ) T5( $T_{amb} < 40\text{C}$ )	---
	Class I Division 2 GP A,B,C,D	---	T5( $T_{amb} < 80\text{C}$ )	---

Table 3. Hazardous Area Classifications for Europe and Asia-Pacific

CERTIFICATION BODY	CERTIFICATION OBTAINED	ENTITY RATINGS	TEMPERATURE CODE	ENCLOSURE RATING
ATEX (LCIE)	(Intrinsic Safety) Ⓔ II 1 G Gas •EEx ia IIC T4/T5	(Main Circuit) $V_{max} = 30 \text{ Vdc}$ $I_{max} = 130 \text{ mA}$ $P_i = 1.0 \text{ W}$ $C_i = 5 \text{ nF}$ $L_i = 0.55 \text{ mH}$	T4( $T_{amb} < 80\text{C}$ ) T5( $T_{amb} < 40\text{C}$ )	---
IECEX (CSA)	(Intrinsic Safety) Gas •Ex ia IIC T4/T5	(Main Circuit) $V_{max} = 30 \text{ Vdc}$ $I_{max} = 130 \text{ mA}$ $P_i = 1.0 \text{ W}$ $C_i = 5 \text{ nF}$ $L_i = 0.55 \text{ mH}$	T4( $T_{amb} < 80\text{C}$ ) T5( $T_{amb} < 40\text{C}$ )	---

FIELDVUE, ValveLink and Fisher are marks owned by Fisher Controls International LLC, a member of the Emerson Process Management business division of Emerson Electric Co. Emerson and the Emerson logo are trademarks and service marks of Emerson Electric Co. HART is a mark owned by the HART Communication Foundation. All other marks are the property of their respective owners.

*The contents of this publication are presented for informational purposes only, and while every effort has been made to ensure their accuracy, they are not to be construed as warranties or guarantees, express or implied, regarding the products or services described herein or their use or applicability. We reserve the right to modify or improve the designs or specifications of such products at any time without notice.*

Neither Emerson, Emerson Process Management, Fisher, nor any of their affiliated entities assumes responsibility for the selection, use and maintenance of any product. Responsibility for the selection, use and maintenance of any product remains with the purchaser and end-user.

### Emerson Process Management

#### Fisher

Marshalltown, Iowa 50158 USA  
Cernay 68700 France  
Sao Paulo 05424 Brazil  
Singapore 128461

[www.Fisher.com](http://www.Fisher.com)

