

# Mobrey 003 Switch

## Ultrasonic liquid level switch



### 003 Ultrasonic switch

- Self contained liquid level alarm
- No moving parts
- European Directive compliance

### Features

- Relay or solid-state output
- Corrosion resistant PPS construction
- 1" or 3/4" threaded mounting
- Small in-tank dimensions
- 24V ac or dc powered
- Lightweight

### Description

Manufactured in Polyphenylene Sulphide (PPS) for corrosion resistance in most liquids, the 003 range of sensors can be mounted in any position in a tank using either a 1" or 3/4" thread available in BSPP, BSPT and NPT thread forms. A thread is provided on each side of a hexagonal boss to allow either external or internal / pole mounting of the sensor.

Comprising a one piece moulded body with an integral pcb, the 003 switch is factory sealed and supplied with a 10ft flying lead for customer connection.

The Mobrey 003 switch is designed for high or low level alarm duties to give a voltage free contact or solid state transistor output for alarm signalling or as part of a pump control system.

### Operation

The moulded body contains two piezo-electric crystals, one each side of a gap at the tip of the sensor.

An ultrasonic signal is transmitted from one crystal into the gap, but if there is air or gas in the sensor gap then the signal is not received by the other crystal. However, if there is a liquid present, the signal will be transmitted across the gap and the integral electronics will switch the output circuitry to signal the presence of a liquid.

### Typical applications

- Low level alarms in header tanks
- Pump control duty in feeder tanks
- High and low alarms in storage tanks
- Level and pump control in storage tanks
- Small or thin wall tanks

### Installation

The 003 sensor may be mounted at any angle in the vessel, although care should be taken to ensure that the liquid is free to drain out of the sensor gap. Position the sensor away from entry or exit points to avoid areas of excessive turbulence or aeration, and avoid installation in the direct flow of liquid.

Ensure a clearance of at least 25mm / 1" from all sensor surfaces to vessel wall to avoid forming air pockets or sludge traps.

A threaded boss is recommended for pressurised applications. Refer to Installation leaflet for full details.

### Dimensional drawing

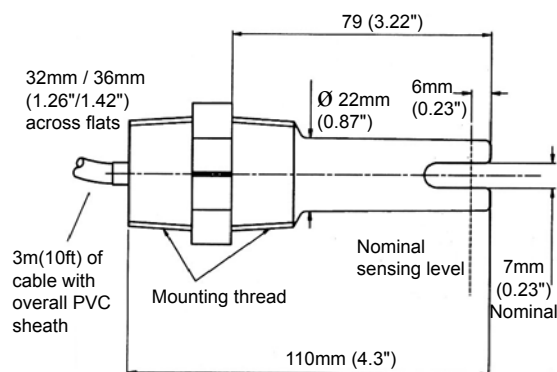

# Level

## Technical specification

	003S* models	003H* models
Operating pressure	20 bar / 290psi	20 bar / 290 psi
Operating temperature	-20°C to +70°C / -4°F to +158°F	-40°C to + 105°C / -40°F to +221°F
Ambient temperature	As operating temp.	As operating temp.
Minimum S. G.	0.50	0.50
Max. viscosity	5000cSt. at 20°C / 68°F	5000cSt. at 20°C / 68°F
Switching response	50ms dry-wet, 0.5s wet-dry	50ms dry-wet, 0.5s wet-dry
Hysteresis	< 4mm / 0.12"	< 4mm / 0.12"
Repeatability	+/- 2mm / 0.08"	+/- 2mm / 0.08"
Overall length	110mm / 4.33"	110mm / 4.33"
Length into tank	79mm / 3.11" (External mount)	79mm / 3.11" (External mount)
Body diameter	22mm / 0.87"	22mm / 0.87"
Switching function	SPCO relay(energised wet)	2 x FET open drain (short circuit protected)
Maximum switched current	1A at 30v res. 0.25A at 30v ind.	100mA max.
Maximum switched voltage	30v	30v
Power supply	18-30v dc or ac	18-30v dc
Dry current drawn	10mA nom.	8mA nom. (4mA min.)
Wet current drawn	25mA max.	16mA nom (20mA max.)
Cable length	3m /10ft :5 core 7/0.2mm(0.008")	3m/10ft : 4 core 7/0.2mm (0.008")
Cable sheathing	PVC	PVC
IP rating of sensor	IP66/IP68 (3m)/ NEMA 6P (10ft)	IP66/IP68 (3m)/ NEMA 6P (10ft)

Not suitable for use in intrinsically safe circuits. Not suitable for the direct starting of large motors.

### Relay output models

Code	Description		
003	Integral ultrasonic level sensor, polyphenylene sulphide construction		
	Code Output type		
S	Integral SPCO relay energised when sensor wet		
	Code Mounting thread Max pressure		
		20°C/68°F	70°C/158°F
0	3/4" BSPT dual	20 bar/290psi	20 bar/290psi
2	1" BSPT dual	20 bar/290psi	20 bar/290psi
5	1" NPT dual	20 bar/290psi	20 bar/290psi

003 S 2 Typical model number

### Solid state transistor output models

Code	Description		
003	Integral ultrasonic level sensor, polyphenylene sulphide construction		
	Code Output type		
H	Two open drain FET transistors, one conducting when sensor wet, one conducting when sensor dry.		
	Code Mounting thread Max pressure		
		20°C/68°F	105°C/221°F
0	3/4" BSPT dual	20 bar/290psi	20 bar/290psi
2	1" BSPT dual	20 bar/290psi	20 bar/290psi
5	1" NPT dual	20 bar/290psi	20 bar/290psi

003 H 2 Typical model number

### Schematic: 003S\* models

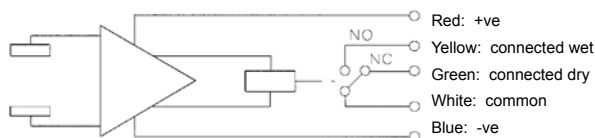

The Emerson logo is a trade mark and service mark of Emerson Electric Co.  
 Rosemount is a registered trademark of Rosemount Inc.  
 Mobrey is a registered trademark of Mobrey Ltd.

All other marks are the property of their respective owners

We reserve the right to modify or improve the designs or specifications of product and services at any time without notice.

#### International:

**Emerson Process Management  
 Mobrey Measurement**  
 158 Edinburgh Avenue, Slough,  
 Berks UK SL1 4UE  
 T +44 (0)1753 756600  
 F +44 (0)1753 823589  
 www.mobrey.com

#### Americas:

**Emerson Process Management  
 Rosemount Inc.**  
 8200 Market Boulevard  
 Chanhassen, MN USA 55317  
 T (US) (800) 999-9307  
 T (International) 952) 906-8888  
 F (952) 949-7001

### Schematic: 003H\* models

