

Mobrey ultrasonic

Liquid level detection systems



Description

Ultrasonic liquid level switches are used in industrial processes, to detect high or low liquid levels.

Operation is achieved using the time proven principle of ultrasonic transmission between two crystals. Liquid presence is detected by virtue of its bulk. Liquid droplets, condensation or foaming are ignored.

Control electronics are available as standard or with ATEX intrinsically safe hazardous area approval with options including lamps to indicate sensor status, time delays and circuits to detect wiring faults.

Contents

System description.....	2
Choice of sensor.....	2
Choice of system and control unit.....	3
Ultrasonic point level sensor dimensions.....	4
Interface detection and sludge measurement.....	5
Standard industrial control units.....	6
Electrosensor systems.....	7
Ultrasonic liquid level sensor selection.....	9
Ordering information.....	10

Features

- No moving parts
- Simple installation
- ATEX Hazardous area approval
- Ignores foams
- Unaffected by:
 - RF Interference
 - Conductivity
 - Droplets
 - Most coatings
 - Liquid colour/opacity



System description

- A Mobrey ultrasonic liquid level control comprises:
- A tank mounted sensor containing transmitter and receiver crystals
 - An RF sensor drive and detector electronic circuit, which may be integral with the sensor or mounted adjacent to the sensor depending upon vessel conditions or access considerations.
 - A control unit mounted remotely to monitor the sensor state and provide the required switching function

Choice of sensor

Mobrey gap sensors

Mobrey gap sensor systems are active when there is a liquid present between the transmitter and receiver crystals of the sensor. In this way, absence of liquid, or damage to cabling will result in a low level being indicated.

Typical applications

- Pump protection
- Vessel empty protection
- Pump control

Ultrasonic sensor operation can be adversely affected by the presence of excessive aeration, solids or foam in the liquid. If you have an application query contact Mobrey for expert advice on the selection of a suitable liquid level detection system.

Sensors may be mounted in any position to signal liquid presence.

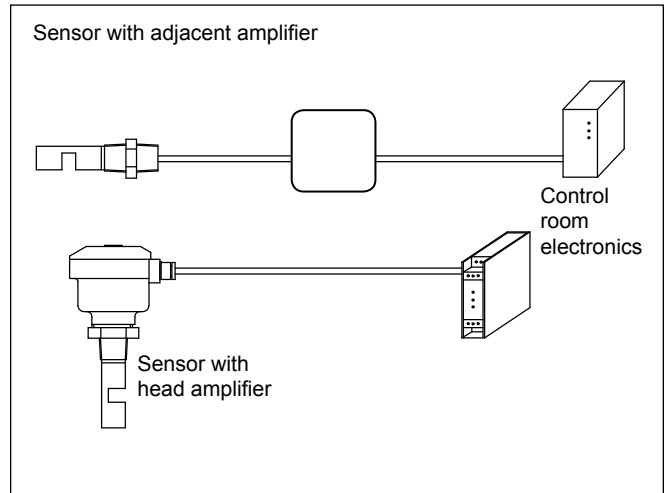

*Mobrey gap sensor:
General purpose failsafe low level*

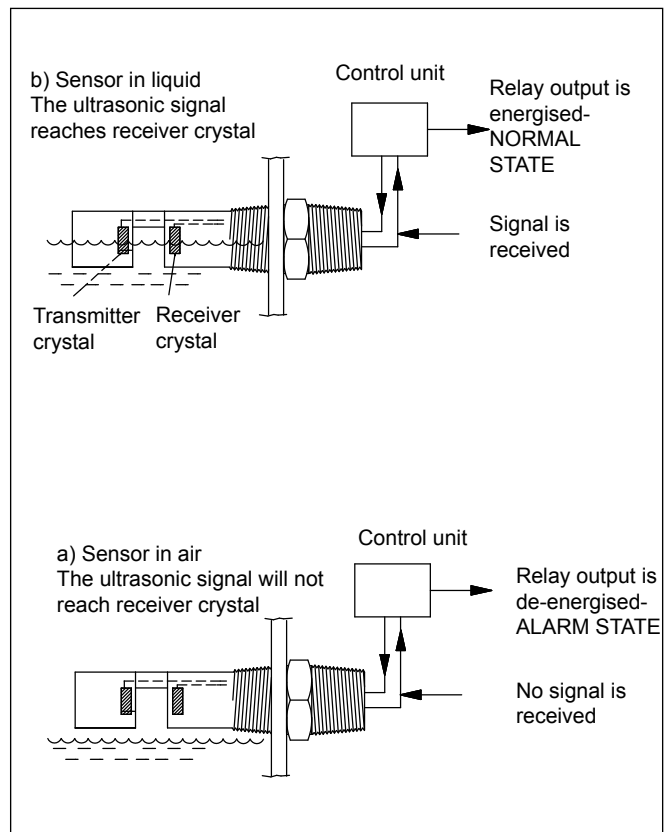

Choice of system and control unit

Select from the 2 systems below the one which meets your needs, then turn to page 9 and select a sensor to suit the liquid in the vessel and your application.

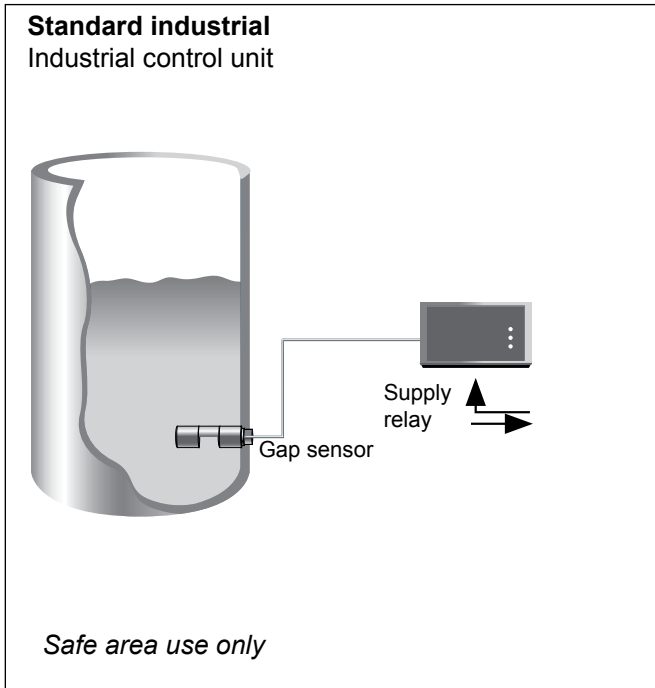

Wall mounting IP65 polycarbonate enclosure
 Connection between sensor and control unit is by up to 50m of dual co-axial cable
 Failure of sensor or breakage of co-axial cable earth loop will cause an alarm condition and light the fault LED. (subject to configuration).



The MCU200 control unit provides simple, economical control electronics for mounting on site near the tanks containing the appropriate ultrasonic sensor. The control unit has a sensitivity potentiometer to adjust for sensor and liquid type.

MCU200 offers in addition a selectable time delay, earth continuity checking between sensor and control unit, and LED's to indicate sensor state. MCU200 has a DPCO relay output and is suitable for use with all Mobrey sensors.

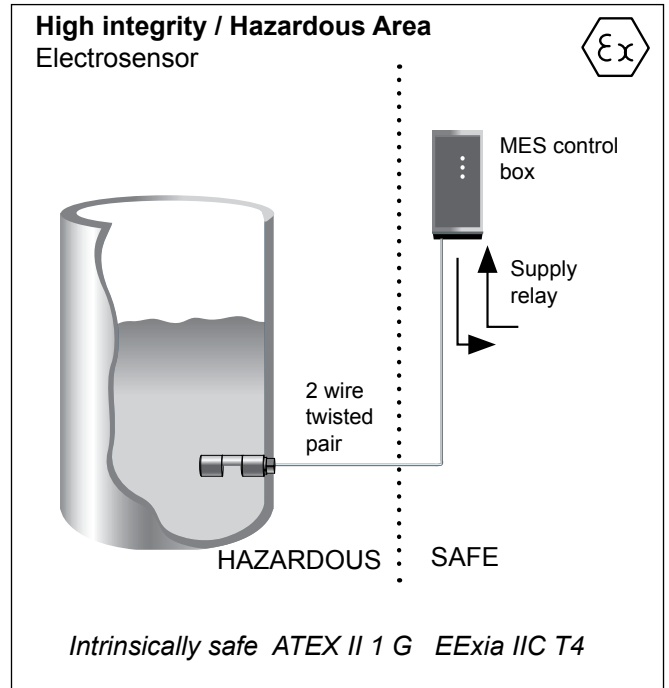

Stand alone electronics
 Simple twisted pair cable between sensor and control unit up to 1000m
 Safe or hazardous area use
 Failure of sensor or cabling will cause an alarm condition and light the fault LED
 Additional fault relay activated on fault condition



Mobrey Electrosensor systems provide a cost effective method of level detection and control where high system integrity coupled with low cost installation is required.

Ultrasonic sensors are fitted with head-mounted or adjacent electronics which are then connected back to control room electronics using simple twisted pair wiring. Sensors may be set to operate either when wet or dry and have a field adjustable sensitivity potentiometer and status LED. All sensors are built to IS standards and may be used in safe or hazardous areas.

Interface detection and sludge measurement

Ultrasonic technology can be used to discriminate between immiscible liquids to indicate the interface and to detect and monitor suspended solids.

Interface detection

For interface detection between immiscible liquids, two techniques are available: ultrasonic attenuation and ultrasonic reflection.

Both techniques use standard Mobrey liquid level control electronic systems. Suitable sensors for interface monitoring are typically the larger gap types i.e. 150mm upwards.

An angle of 10 degrees is chosen and often this results in total internal reflection of the transmitted beam. Thus when the interface is within the gap of the angled sensor, very little ultrasound reaches the receiver, but when the interface is above or below the sensor (ie in either liquid) then there is a large signal present. The control unit gain is set to actuate the relay when the interface is in the gap. Note this condition will also occur if the upper liquid drains away and air (gas) is in the gap. Note for further information on suitability of this application consult our technical sales.

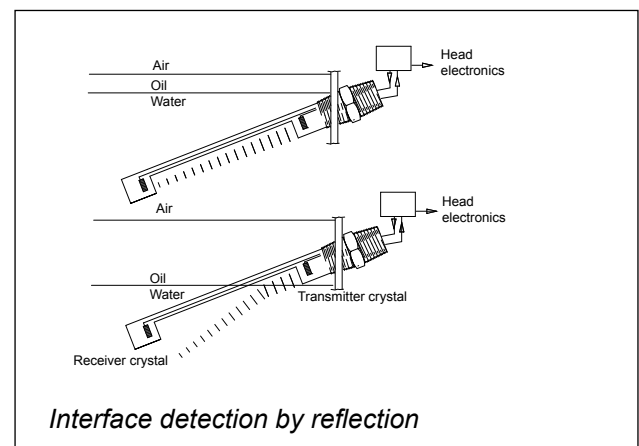
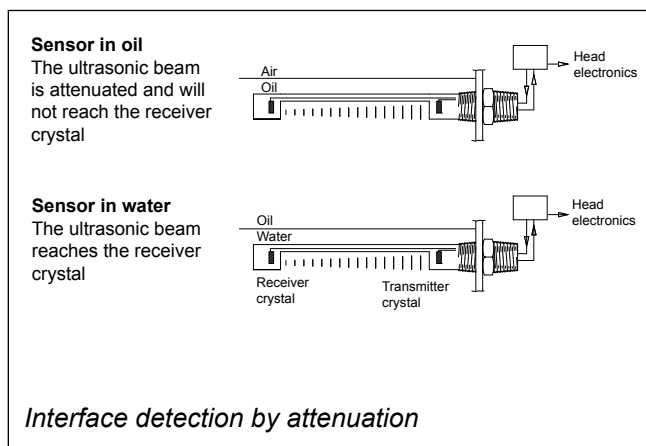

Ultrasonic attenuation is the reduction in energy of the beam as it is transmitted through the liquid. Viscous liquids, emulsions and liquids with entrained solids generally have a higher ultrasonic attenuation than low viscosity clear liquids such as water. When the attenuation difference is sufficient, the amplifier gain can be adjusted so that the ultrasound beam passes through the less attenuative liquid but is stopped by the more attenuative liquid. The output relay can then be set to monitor which liquid is in the gap.

When two immiscible liquids have similar attenuations the above method cannot be used, however it is likely that the velocity of ultrasound will be different. In this case a beam of ultrasound passing through the interface will be reflected and refracted and if the sensor is arranged at a shallow angle the effect is that the transmitted beam tends to miss the receiver and is thus effectively attenuated.

Suspended solids measurement

Solids suspended in a liquid will scatter ultrasonic beams, causing attenuation. This attenuation depends on the size and nature of the particles and for typical sewage sludges it is possible to use Mobrey ultrasonic systems to detect 1% to 15% w/w. Industrial slurries such as fine pottery slips can often be measured to 65%, but coarse granular material is often very attenuative. Leaflet IP250 gives details of Mobrey sludge measurement systems.

Interface and sludge monitoring

Typically sensors with gaps of 150mm or larger are used for interface and sludge measurement. These sensors are standard types 402, 433 and the 442 (a pair of sensors for mounting across or along a pipe section). Special flanged sensors with the 10 degree tilt built in are also available. Generally these sensors work at 3.7MHz and are compatible with Electrosensor electronics or plant mounted MCU200 electronics.

Mobrey standard industrial control unit MCU200

- Simple economical control unit
- IP65 enclosure
- 115v/230v AC or 24v DC

- Features: Sensor status LED
Time delay
Cable check
Pump control



Description

The MCU200 control unit provides simple, economical control electronics for mounting on site near the tanks containing the appropriate ultrasonic sensor. The sensors provide liquid level detection, and are available in various materials and mechanical designs. (See page 9).

The control unit provides a relay output for external control or alarm functions according to whether the sensor is wet or dry. The MCU200 has a dual pole relay output energised when the sensor is wet, LED indicators, time delays and cable check facilities preselectable. The MCU200 will operate with all Mobrey ultrasonic sensors and can accept a voltage free contact input from another level switch to give a pump control function on the output relay.

Installation

Mobrey ultrasonic sensors are normally fitted with dual coaxial cable. This cable can be extended with suitable coaxial extensions up to 50 metres. Suitable cable is part No. K178, or two lengths of coax type RG178 can be used.

The coaxial cables are terminated in the control unit. The output cabling from the control unit comes from the relay output terminals as a wet/dry changeover switch. This can be used to trigger an alarm or provide an input into a control system.

	MCU201	MCU203
Power supply (Selector switch)	110/120V ac 220/240V ac	24V dc earthed negative
Power consumption	6VA	0.1A
Relay output	DPCO	
Relay rating	5A at 230V	
Box dimensions	200 x 120 x 75	
Box rating	IP65 Polycarbonate	
Holes for glands	3 off 16mm dia,	
Fixing centres (WxH)	188 x 88mm	
Fixing hole diameter	4mm	

Technical data

MCU200 Features	Suitable for all Mobrey ultrasonic point sensors
Frequency selection	By switch on PC board
Relay	Energised for sensor wet or dry selectable by switch
LED indicators	Visible through the box lid. Green for normal. Red for alarm. Selectable for wet/dry sensor as appropriate for the application. Amber LED for fault condition
Gain potentiometer	Fitted with scale and separate range switch to adjust for sensor type and site conditions.
Response time	Selectable delay of 0.5, 2, 8 or 30 seconds. Delay selectable wet to dry or dry to wet. 50 ms response in opposite direction
Sensor cable check	Selectable to monitor coax screen to sensor for continuity. Fault lights fault LED and sets relay to alarm state
Auxiliary input	External closed circuit input to MCU200 latches the output relay to achieve pump control

Electrosensor systems

Description

An Electrosensor system comprises an ultrasonic sensor with head electronics either mounted directly on the sensor or in an adjacent wall mount box, and control room electronics. Connection between sensor electronics and control electronics is by standard twisted pair instrument cable, typically over distances up to 1000m.

Control room electronics

- Provides intrinsically safe power supply to sensor electronics and detects sensor state.
- Operates output relays and front panel LEDs
- Monitors plant wiring integrity

Principle of operation

The twisted pair supplies a DC voltage from control electronics to the sensor. The current drawn by the sensor is used to signal the sensor state. This current signalling is detected by a trip amplifier in the control electronics.

The control electronics include a fault monitoring circuit to detect if the current drawn is outside preset limits, such as would occur on cable breakage or short circuit. Electrosensor can be used in all areas of the plant. Some users may prefer to provide their own supply and alarm circuits.

Electrosensors are fully system certified to accommodate this need, enabling connection to PLC or other control circuits via standard Zener safety barriers when the sensor is in a hazardous area.

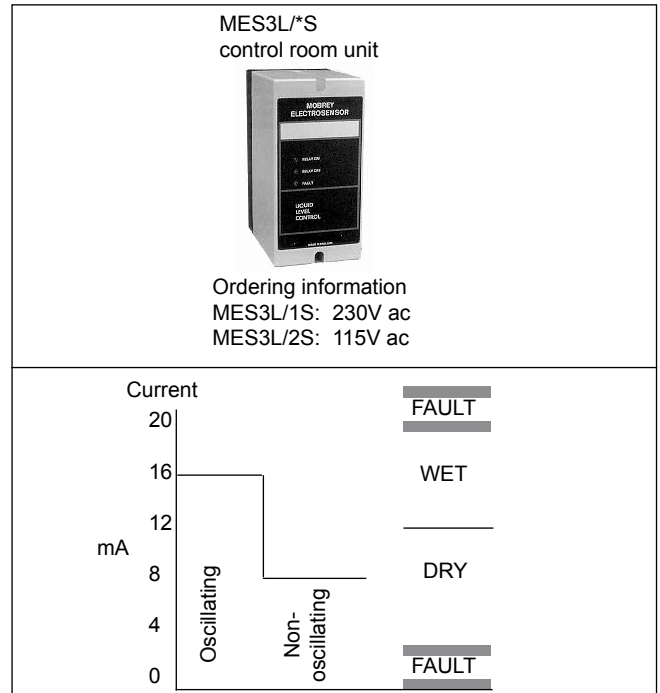

Specification

Common specifications

Design concept	Will de-energise relay on loop current levels falling outside of preset limits (i.e. open or short circuit) All control room electronics have visible LEDs to indicate sensor and fault detection circuit status.
LED indicators	3 off: Alarm relay on, Alarm relay off, fault detected
Approval	ATEX II(1)G [EExia] IIC (MES2D/3S requires separate external safety barriers ATEX II (1) G for connection to the sensor in a hazardous area.)

Stand alone electronics: MES3L/*S

Alarm relay output	Operates one electrosensor or two sensors for pump control Selectable: energised for sensor wet or sensor dry using PCB switch. When two sensors are connected, relay assumes a pump control function and PCB switch selects whether the relay is energised to fill or empty the tank between the two sensors
Fault relay output	De-energises on fault condition. PCB switch to select whether the fault condition also de-energises the alarm output relay.
Relays (2)	SPCO 100V A max/ 5 A max.
Cable entry	Via base cutouts through rubber grommets to terminal strip.
Voltage	MES*L/1S: 230V ac 50/60Hz MES*L/2S: 115V ac 50/60Hz
Output to sensor	Mains powered units: 12v DC intrinsically safe, fully floating (galvanically isolated)
Delay	0.5s wet to dry 50ms dry to wet
Ambient temp.	60°C
Power consumption	8VA
Protection	IP20
Power supply tol.	AC mains +/- 10%

Electrosensor head electronics

Most of the sensors on page 4 can be specified with Electrosensor electronics. 1 MHz sensors with dual screwed fittings can be specified with head mounted electronics housed in a tough nylon enclosure integral with the sensor. A field adjustable gain potentiometer and an LED indicator, visible through the end cover to show sensor status are provided. A selector switch to set the 16mA signal to occur either with the sensor wet or dry is also provided. A terminal with PNP output allows direct connection to a PLC input via a third signal wire.

Sensor head electronics are also available in an adjacent wall mounting enclosure, for use with any 1MHz or 3.7MHz sensor. These electronics are used where it is not possible or desirable to mount the electronics directly on the sensor. Connections between adjacent electronics and sensor is by dual coaxial cable (maximum length 10m).

Head mounted (integral) electronics

Mounted in a tough glass filled nylon enclosure weatherproof to IP66/IP67 the head electronics drive the sensor and detect its state; either wet or dry. Connection is via the M16 cable gland (supplied). Removal of the housing cover reveals:

- Adjustable gain potentiometer to set the sensor to suit application conditions.
- Mode selector switch.
- Connections for control electronics.
- LED to indicate sensor state (visible through window in end cover)

Specification

Hazardous area approval	Electrosensors are approved intrinsically safe ATEX II 1 G EExia IIC T4 (-40°C ≤ Ta ≤ +85°C) or T5 (-40°C ≤ Ta ≤ +40°C) and can be used with control room electronics (Page 9) or used in an intrinsically safe system
Power input:	12 -24V DC from associated MES control room electronics or other suitably protected source
Sensing:	Draws either 8 or 16mA on a current loop dependent on sensor state and mode switch setting
Mode selector	Gives choice of current level for sensor state. Would typically be set for 16mA with sensor switch oscillating (i.e gap sensor wet, Hi-sens dry)
Output selection	Both types of head amplifier have a transistor output on a third terminal, suitable for signalling to a PLC or similar device. This transistor output switches upto 30mA at the supply line voltage onto the third wire
Ambient temp.	- 40°C to + 60°C
Earthing	Head electronics are floating with respect to sensor body. Sensor body may be earthed through tank connection.
Plant cabling	Standard twisted pair instrument cable recommended with screen (screen not connected at head electronics). Maximum loop resistance 30 ohms. Cable parameters must conform to ATEX requirements
Users own electronics	Electrosensors on this page can be used in any intrinsically safe system The user must ensure that suitable safety barriers are used.

Head electronics



The Electrosensor model no. as selected from page 9 includes head electronics, code SSH.

Adjacent electronics: MES3AI



Suitable sensor must be selected from page 9 code U8H only

Adjacent mounted electronics

The sensor drive and detector electronics are enclosed in a wall mounted IP65 polycarbonate box which is wired to the sensor using dual co-axial cable (maximum length 10m). Connection is via 2 M16 cable glands (supplied). Removal of the box lid reveals:

- Sensor frequency selector switch (1MHz or 3.7MHz)
- Coarse and fine grain adjustment to set the sensor to suit application conditions.
- Mode selector switch.
- Connections for sensor and control electronics.
- Output selector switch for 8-16mA current loop operation. If PLC operation is selected, current drawn is set to approximately 8mA in both sensor states (wet or dry).
- LED to indicate sensor state (visible only when box lid removed).

Ultrasonic liquid level sensor selection

Code	Fitting	Wetside Material	Design or Duty	Liquid Type	Temperature	Pressure	Sensor active
332SD	1" BSPT dual	316 st.st (cast)	Standard	Clean	-70°C to +150°C	56b	Wet
302SD	¾" BSPT dual	316 st.st (cast)	Standard	Clean	-70°C to +150°C	105b	Wet
402SD	¾" BSPT dual	316 st.st (cast)	Interface duty	Clean	-70°C to +150°C	105b	Wet or clear
433SD	¾" BSPT inside	316 st.st (cast)	Interface duty	Clean	-70°C to +50°C	105b	Wet or clear
442SD	¾" BSPT dual	316 st.st (cast)	Across pipeline	Clean	-70°C to +150°C	105b	Wet or clear

Most sensors are available with flange mounting. Consult factory for details.

Sensor operation may be upset by highly aerated or heavily contaminated liquids. Consult factory if in doubt.

For pressure above 50 bar, always consult factory before specifying.

CODE	Sensor compatibility with Mobrey Systems	
	Compatible control system	

80	Control boxes MCU	Standard with 3m Cable, non approved	
U8H	Electrosensor MES	ATEX approved. For use with adjacent head amplifier*	
SSH	Electrosensor MES	ATEX approved. Fitted with integral head amplifier	Not permissible with 442SD

CODE	Standard Options	Permissible with	Not permissible with
E	Sensors available in extended length versions Specify dimension 'A' (See page 4) when ordering For horizontal sensor mounting, Max 'A' = 915mm For vertical sensor mounting, Max 'A' = 3000mm	302 only	332 402, 442, 433
1-5	Specifies sensor gap size on 433 Type: 1 = 100mm: 2 = 200mm 3 = 300mm: 4 = 450mm 5 = 150mm	433 only	302, 332, 402, 442

CODE	Special Options
X123 or M1	A suffix in the form X*** may be used where a special option is supplied When ultrasonic crystals with a non-standard operating frequency are supplied, the suffix used will be in the form M*.

302SD 80 (These characters only used if required)

Full details of Mobrey ultrasonic sensors for use in sludge blanket level or sludge density measurements are given in leaflet IP250

Notes:

Carbon dioxide (CO2): ultrasonic gap sensors will not operate in liquid CO2, which is highly attenuative.

Electrosensor ordering information

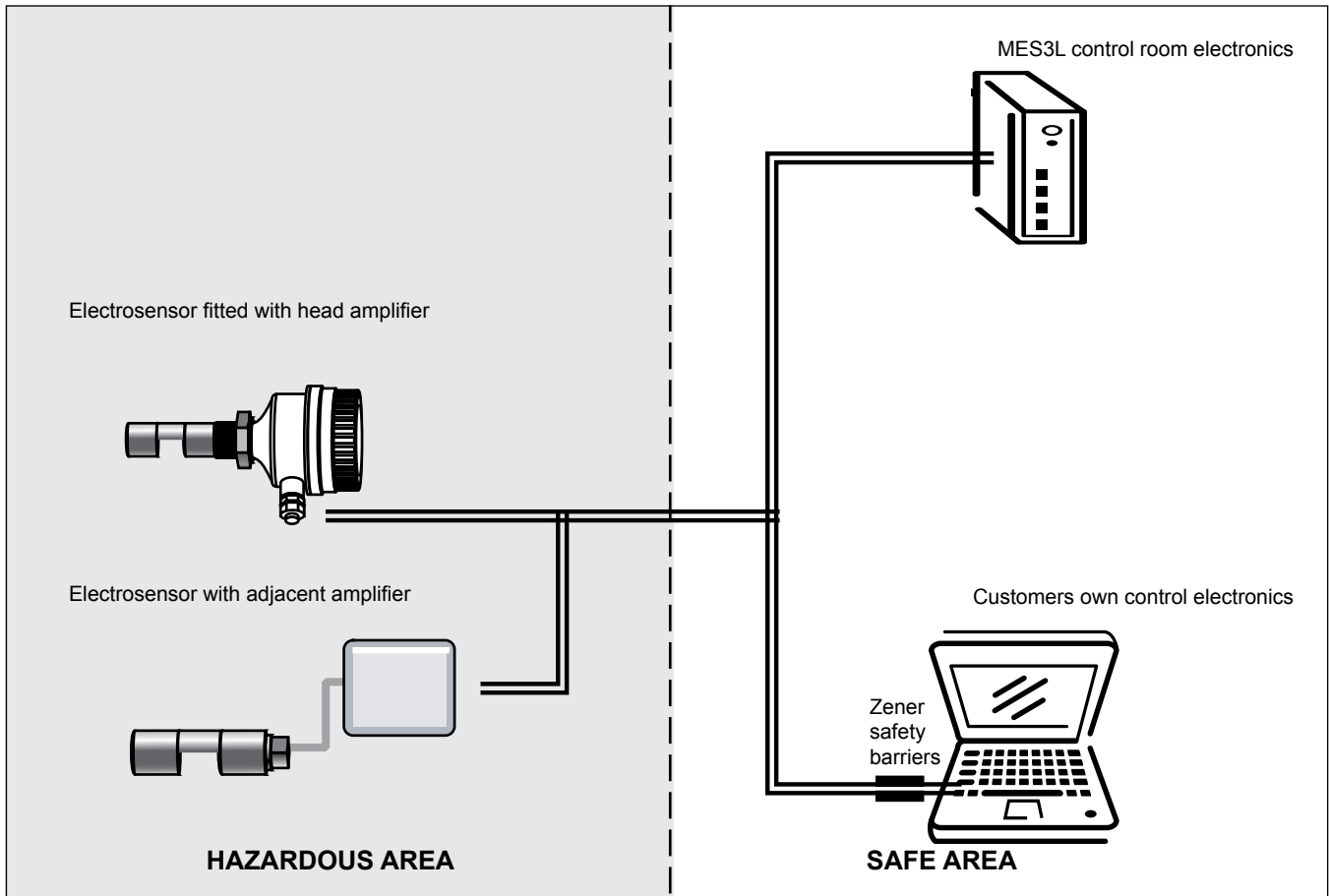

Ordering information - control room electronics

MES	Mobrey Electrosensor
	Code Approvals
	3 Intrinsically safe (type L enclosure only)
	Code Enclosure
	L Stand alone enclosure
	Code Voltage input
	1 230V ac MES3L only
	2 115V ac MES3L only
	Code Relay output
	S SPCO

↓ ↓ ↓ ↓ ↓
 MES 3 L / 1 S Typical model number

Ordering information - control room electronics

Sensor	Page 9	Select type ***SDU8H*
Head amplifier	MES3AI	

Ordering information - control room electronics

Sensor/amplifier	Page 9	Select type ***SDSSH*
------------------	--------	-----------------------

The Emerson logo is a trade mark and service mark of Emerson Electric Co.
Mobrey is a registered trademark of Mobrey Ltd.
All other marks are the property of their respective owners
We reserve the right to modify or improve the designs or specifications of product and services at any time without notice.

International:

Emerson Process Management

Mobrey Measurement

158 Edinburgh Avenue, Slough,

Berks UK SL1 4UE

T +44 (0)1753 756600

F +44 (0)1753 823589

www.mobrey.com

