

Temperature Sensors and Accessories (Metric)

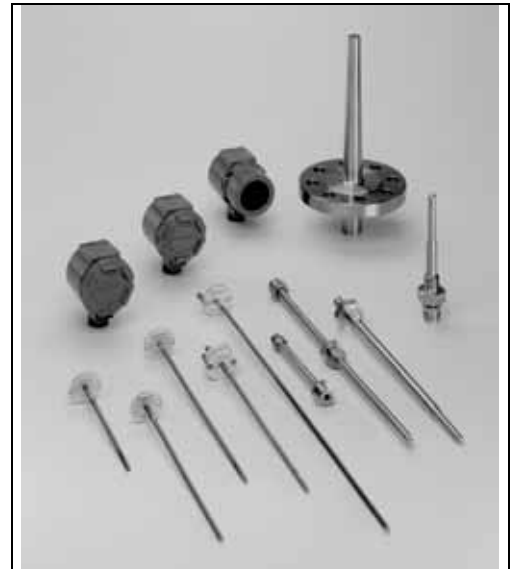

Content

Introduction	page 2
Integral Mount Sensors and Assemblies	page 3
Mounting Configurations	page 3
Specifications	page 4
Hazardous Locations Certification	page 5
Sensor-to-Transmitter Matching	page 6
Calibration	page 7
Ordering Tables	page 9
Series 65 and 185 Without Thermowell	page 9
Series 65 and 185 With Tubular Thermowell	page 12
Series 65 and 185 With Barstock Thermowell	page 15
Series 96 Barstock Thermowell	page 20
Accessories	page 17
Thermowell Strength Calculation	page 22
Application Data Sheet	page 23

Sensors and Accessories (Metric)

Introduction

Overview

Rosemount integral mount temperature sensors, accessory hardware, and assemblies constitute a complete line of industrial temperature-sensing instruments. A variety of RTD and thermocouple sensors are available alone, or as complete assemblies including connection heads, thermowells, and extension fittings. Emerson Process Management (“Emerson”) offers a complete temperature measurement assemblies including Rosemount Smart and Programmable Temperature Transmitters. Please ask your Emerson representative for details.

Series 65 Platinum RTD Temperature Sensors are highly linear and have a stable resistance versus temperature relationship. These sensors are used primarily in industrial environments where high accuracy, durability, and long-term stability are required. Series 65 sensors are designed to meet the most critical parameters of international standards: DIN EN 60751 incorporating Amendments 1 and 2, DIN 43760, and BS 1904.⁽¹⁾ This standardization provides sensor interchangeability without the need for transmitter circuitry adjustment.

Enhanced performance and optimal temperature measurement accuracy is available for Series 65 sensors coupled with a range of smart temperature transmitters through calibration schedules and Callendar van Dusen constants.

Series 185 Thermocouple Temperature Sensors conform to IEC 584 and are available in types J, K and N. Series 185 sensors are available single ungrounded, or dual ungrounded, isolated.

All sensors are available in a variety of lengths⁽²⁾ and ranges with flying lead, terminal block, or 1/2-inch ANPT spring-loaded adapter lead wire terminations.

In addition to complete assemblies, Emerson offers a selection of separate accessory hardware including connection heads and thermowells.

Choosing an Extension and Thermowell

Aside from ambient temperature variations, heat from the process, in a direct mounting configuration, is transferred from the thermowell to the transmitter housing. If the expected process temperature is near or beyond the transmitter specification limits, consider the use of additional thermowell extension length, an extension nipple, or a remote mounting configuration to isolate the transmitter from these excessive temperatures. Figure 1 provides an example of the relationship between transmitter housing temperature rise and extension length. Use Figure 1 and the accompanying example as a guide for determining adequate thermowell extension length.

FIGURE 1. Transmitter Housing Temperature Rise vs. Uninsulated Extension Length

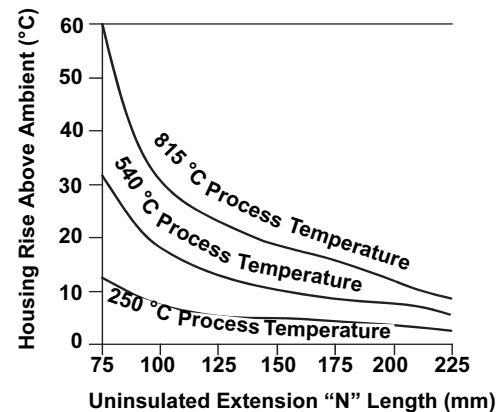

Example

The rated ambient temperature specification for the transmitter is 85 °C. If the maximum ambient temperature is 40 °C and the temperature to be measured is 540 °C, the maximum allowable housing temperature rise is the rated temperature specification limit minus the existing ambient temperature (85 – 40), or 45 °C.

As shown in Figure 1, an “N” dimension of 90 mm will result in a housing temperature rise of 22 °C. An “N” dimension of 100 mm would therefore be the minimum recommended length, and would provide a safety factor of about 25 °C. A longer “N” dimension, such as 150 mm, would be desirable in order to reduce errors caused by transmitter temperature effect, although in that case the transmitter may require extra support.

(1) 100 Ω at 0 °C, $\alpha = 0.00385 \Omega \times \text{°C}/\Omega$

(2) Sensors over two meters long will be supplied coiled unless otherwise requested.

Product Data Sheet

00813-0200-2654, Rev HA

February 2008

Sensors and Accessories (Metric)

INTEGRAL MOUNT SENSORS AND ASSEMBLIES

Series 65 RTD and Series 185 Thermocouple Temperature Sensors may be ordered as complete assemblies, which provide a complete, yet simple, means of specifying the proper industrial hardware for most temperature measurements. One assembly model number, derived from one ordering table, completely defines the type of sensing element, as well as the material, length, and style of extension fittings and thermowells.

All sensor assemblies are sized and inspected by Emerson to ensure complete component compatibility and performance.

MOUNTING CONFIGURATIONS

Series 65 Platinum RTDs and Series 185 Thermocouples

You may order the Series 65 RTDs and the Series 185 Thermocouples with flying leads, a terminal block, or a 1/2-inch ANPT spring-loaded adapter.

Ordered with flying leads, the sensors are designed to be used with a head-mount temperature transmitter attached directly to the sensor. The flying lead configuration allows the removal of the sensor and transmitter as one assembly.

The BUZH connection head allows terminal block style sensors and transmitters to be mounted together. The transmitters in these assemblies will be mounted in the cover of the BUZH connection head.

The sensors with a 1/2-inch ANPT spring-loaded adapter are used with directly mounted 3144P field-mount temperature transmitters or through the use of Rosemount connection heads. This assembly requires a terminal block to be mounted inside the head.

Hazardous area approvals are available with all three types of sensors, but they are dependent on the configuration of the entire temperature measurement assembly (see "Hazardous Locations Certification" on page 5).

Temperature Considerations

Ambient temperature limits for the connection head are -40° C to +85° C. The LT Option may be extended down to a range of -51° C to +85° C.

Ambient temperature range addresses the connection head only, and requires suitable cable glands and field wiring provisions to meet the temperature requirements below -40° C.

FIGURE 2. Series 65 RTD Lead Wire Configuration

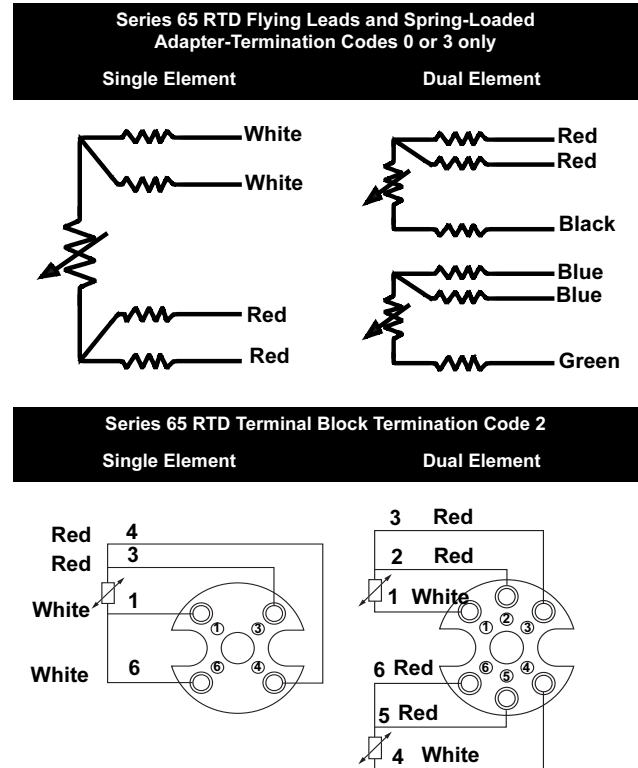
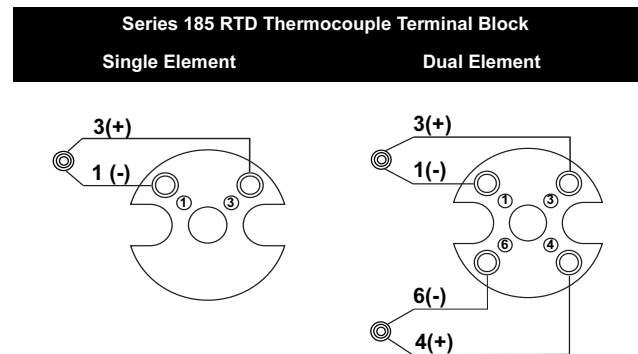

FIGURE 3. Series 185 Lead Wire Configuration



Sensors and Accessories (Metric)

SPECIFICATIONS

Series 65 Platinum RTD

100 Ω RTD at 0 °C,
 $\alpha = 0.00385 \Omega \times \text{°C}/\Omega$

Temperature Range

–50 to 450 °C or –196 to 600 °C depending on type

Self Heating

0.15 K/mW when measured per method defined in
 DIN EN 60751:1996

Thermal Response Time

9 seconds maximum required to reach 50% sensor response
 when tested in flowing water according to IEC 751

Immersion Error

60 mm minimum usable depth of immersion when tested
 according to IEC 751

Insulation Resistance

1,000 MΩ minimum insulation resistance when measured at 500
 Vdc and at room temperature

Sheath Material

316 SST / 321 SST with mineral-insulated cable construction

Lead Wire

PTFE insulated, silver-coated copper wire. See Figure 3 for wire
 configuration

Identification Data

The model and serial numbers are marked on each sensor

Ingress Protection (IP) Ratings

Rosemount Series 65 sensor assemblies are IP65 / IP68 and
 NEMA 4X. This rating is applicable only for complete assemblies
 including either:

- a connection head, extension, and barstock thermowell
- a connection head and tubular thermowell
- a connection head, extension, and sensor

Series 185 Thermocouple

Construction

A thermocouple consists of a junction between two dissimilar
 metals that produces a change in thermoelectric emf in
 relationship to a change in temperature. Rosemount Series 185
 thermocouple sensors are manufactured from selected materials
 to meet IEC 584 Tolerance Class 1. The junction of these wires is
 welded to form a pure joint, maintaining the integrity of the circuit
 and ensuring the highest accuracy. Ungrounded junctions are
 protected from the environment by the sensor sheath. The
 ungrounded and isolated junctions provide electrical isolation from
 the sensor sheath.

Sheath Material

Rosemount thermocouples are made of a mineral insulated cable
 design with a variety of sheath materials available to suit both the
 temperature and the environment. For temperature up to 800 °C in
 air, AISI 321 is standard. For temperatures from 800 to 1100 °C in
 air, Inconel 600 is standard. For temperatures above 1100 °C,
 precious metal or ceramic protective sheaths are available upon
 request. For strongly oxidising or reducing atmospheres, please
 consult your local Emerson representative.

Lead Wires

Thermocouple, internal – 18 SWG (16 AWG) solid wire (max), 19
 SWG (18 AWG) solid wire (min.). External extension leads, Type J
 and K – 0.8 mm minimum stranded wire, PTFE insulated. Color
 coded per IEC 584. See Figure 3 for wire configuration.

Identification Data

The model and serial numbers are marked on each sensor.

Insulation Resistance

1 000 MΩ minimum insulation resistance when measured at 500
 Vdc and at room temperature.

Ingress Protection (IP) Ratings

Rosemount Series 65 sensor assemblies are IP65 / IP68 and
 NEMA 4X. This rating is applicable only for complete assemblies
 including either:

- a connection head, extension, and barstock thermowell
- a connection head and tubular thermowell
- a connection head, extension, and sensor

TABLE 1. Characteristics of Series 185 Thermocouples

Type	Alloys (wire colour)	Sheath Material	Temp. Range (°C)	Limits of Error Interchangeability DIN EN 60584-2	Tolerance Class
J	Fe (+ black), CuNi (– white)	1.4541 (AISI 321)	– 40 to 375, 375 to 750	1.5 °C, 0.004 t	1
K	NiCr (+ green), NiAl (– white)	Inconel 600	– 40 to 375, 375 to 1000	1.5 °C, 0.004 t	1
N	NiCrSi (+ rose), NiSi (– white)	Nicrobell B	– 40 to 375, 375 to 1000	1.5 °C, 0.004 t	1

Product Data Sheet

00813-0200-2654, Rev HA

February 2008

Sensors and Accessories (Metric)

HAZARDOUS LOCATIONS CERTIFICATION

E1 ATEX/CENELEC Flameproof Approval
ATEX Marking Ex d IIC T6 II 2 G
Certification Number. KEMA99ATEX8715
EEx d IIC T6 ($T_{\text{amb}} = -40$ to 65 °C).

The ATEX/CENELEC Flameproof approval is dependent on the Rosemount Integral Sensor Connection Head assembled with a Rosemount RTD or thermocouple temperature sensor (see Figure 4). The captive flame arrestor insert must be fully engaged into the connection head for compliance with this approval.

ATEX Flameproof Approval
ATEX Marking Ex d IIC T5 II 2 G
Certification Number. KEMA01ATEX2181.
EEx d IIC T5 ($-40 \leq T_{\text{amb}} \leq 80$ °C)
EEx d IIC T6 ($-40 \leq T_{\text{amb}} \leq 70$ °C)

The Rosemount Series 65 RTD and 185 Thermocouple Temperature Sensors with $\frac{1}{2}$ -inch ANPT Spring Loaded Adapters are approved for direct mount to the Rosemount 3144P Smart Temperature Transmitters. Refer to the Rosemount Temperature Transmitter Reference Manuals for installation details.

FIGURE 4. ATEX/CENELEC Flameproof Configuration.

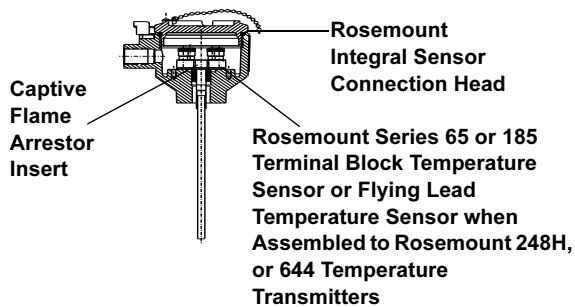

ND ATEX / CENELEC Dust Ignition-Proof
Certification Number: KEMA99ATEX8715
ATEX Marking: Ex tD II 1 D
CE 1180
 T_{95} °C (-40 °C $\leq T_{\text{amb}} \leq 85$ °C)
IP66

The ATEX/CENELEC Dust Ignition-Proof approval is dependent on the Rosemount Integral Sensor Connection Head assembled with a Rosemount RTD or thermocouple temperature sensor (see Figure 4). The captive flame arrestor insert must be fully engaged into the connection head for compliance with this approval.

N1 ATEX/CENELEC Type "n" Approval
ATEX Marking Ex nL IIC T5 II 3 G
Certification Number BAS00ATEX3145
[EEx nL II T5 ($T_{\text{amb}} = -40$ to 70 °C)]

The ATEX/CENELEC EExn Approval allows equipment, which under normal conditions does not emit sparks or produce hot surfaces, to be installed in Zone 2 areas. The EEx n integrity is achieved by the design and construction that maintains a minimum of IP 54 protection. Individual items are not approved. The Rosemount type n approval applies to complete assemblies only. This approval applies to every combination of thermowell, connection head, extension, and sensor detailed in this Product Data Sheet, except the $\frac{1}{2}$ -inch ANPT spring-loaded style. In addition, certain thermowells, not designed by Rosemount Inc., are acceptable for the EEx n assembly provided they conform exactly to Rosemount specifications.

I1 ATEX/IBExU Intrinsic Safety Approval
ATEX Marking Ex ia IIC T6 II 2 G
EEx ia IIC T6 ($T_{\text{amb}} = -51$ to 60 °C)
The Intrinsically Safety Approval is valid for Series 65 RTD Sensors and Series 185 thermocouples.

These certified sensors can only be applied in Zone 1. The marking of intrinsically safe circuits is effected by color codes or print, Ex i. A mounted-on connection head is provided with a ground screw for earth connection and a blue painted cable gland.

E5 FM Explosion-Proof
Explosion-Proof for Class I, Division 1, Groups B, C, D.
Dust-Ignition Proof for Class I, III, Division 1, Groups E, F, G.
Ambient temperature Limits: -40 to 245 °C
When installed per Rosemount Drawing 000068-0013
NEMA Enclosure Type 4X.

E7 Standard Association of Australia (SAA) Flameproof Approval
(EEx d IIC T6 ($T_{\text{amb}} = -40$ to 65 °C))
The Rosemount Series 65 RTD and Series 185 Thermocouple Temperature Sensors are approved for direct mount to the Rosemount 248H, 644, and 3144P Smart Temperature Transmitters. To ensure approval compliance, specify the E7 option of both the sensor and the transmitter at the time of ordering.

Sensors and Accessories (Metric)

SENSOR-TO-TRANSMITTER MATCHING

Significant measurement accuracy improvements can be attained using a temperature sensor that is matched to a temperature transmitter. This process involves identifying the relationship between resistance and temperature for a specific RTD sensor. This relationship, approximated by the Callendar-van Dusen equation, is described as:

$$R_t = R_o + R_o\alpha[t - \delta(0.01t - 1)(0.01t) - \beta(0.01t - 1)(0.01t)^3],$$

where:

- R_t = Resistance (ohms) at Temperature t (°C)
- R_o = Sensor-Specific Constant (Resistance at $t = 0$ °C)
- α = Sensor-Specific Constant
- δ = Sensor-Specific Constant
- β = Sensor-Specific Constant (0 at $t > 0$ °C)

The exact values for the Callendar-van Dusen constants (R_o , α , δ , β) are specific to each RTD sensor and are established by testing each individual sensor at various temperatures.

Series 65 RTD sensors can be ordered with the Calibration Option codes V10 or V11, where the values of all four sensor-specific constants are supplied with each sensor. To utilize the unique, built-in sensor-matching capability of the Rosemount 644, and 3144P transmitters, the Callendar-van Dusen constants can be programmed into the transmitter at the factory or in the field using a HART Communicator.

The transmitter uses the Callendar-van Dusen constants to generate a sensor curve that describes the relationship between resistance and temperature for this particular sensor and transmitter assembly. By using the sensors actual resistance-vs.-temperature curve, there is a 3- or 4-fold improvement in temperature measurement accuracy for the total system.

Options V10 and V11 are specific to a particular temperature range. As with Calibration Schedules, the accuracies associated with each option code represent worst-case conditions when the sensor is used over the entire temperature range. The accuracy of Series 65 sensors with the “V” option will vary because they have different hysteresis and repeatability characteristics. To ensure optimal performance, select a “V” option where the sensor’s range of actual operation is between the minimum and maximum calibration points. For applications requiring the use of a Resistance vs. Temperature Table, order a temperature range-specific characterization schedule.

IEC 751 Interpretation

The Callendar-van Dusen equation is one method of describing the resistance versus temperature (R vs.T) relationship for platinum RTDs. International standard IEC 751 interprets the R vs. T relationship using an approach similar to the Callendar-van Dusen methodology. The IEC 751 R vs.T relationship standard uses the following equation:

$$R_t = R_o[1 + At + Bt^2 + C(t-100)t^3]$$

As in the Callendar-van Dusen method, R_o , A, B, C are specific to each RTD and are established by testing each sensor at various temperatures. The actual values for A, B, and C differ in magnitude from the Callendar-van Dusen constants (R_o , α , β , δ), while R_o is the same in both equations. Either methodology yields the same result in any sensor-to-transmitter matching scenario, since one equation is a simple mathematical interpretation of the other.

TABLE 2. Series 65 Interchangeability

Standard Series 65 IEC-751 Class B	Temperature
±0.80 °C (±1.44 °F)	-100 °C (-148 °F)
±0.30 °C (±0.54 °F)	0 °C (32 °F)
±0.80 °C (±1.44 °F)	100 °C (212 °F)
±1.80 °C (±3.24 °F)	300 °C (572 °F)
±2.30 °C (±4.14 °F)	400 °C (752 °F)
Series 65 with IEC-751 Class A Option	Temperature
±0.35 °C (±0.63 °F)	-100 °C (-148 °F)
±0.15 °C (±0.27 °F)	0 °C (32 °F)
±0.35 °C (±0.63 °F)	100 °C (212 °F)
±0.75 °C (±1.35 °F)	300 °C (572 °F)
±0.95 °C (±1.71 °F)	400 °C (752 °F)

Product Data Sheet

00813-0200-2654, Rev HA

February 2008

Sensors and Accessories (Metric)

Typical Sensor-to-Transmitter Matching Accuracy Improvements

Transmitter: Rosemount 3144 (has built-in sensor matching capabilities), span of 0 to 200 °C, accuracy = 0.1 °C)

Sensor: Series 65 RTD

Callendar van Dusen Option: V10

Process Temperature: 150 °C

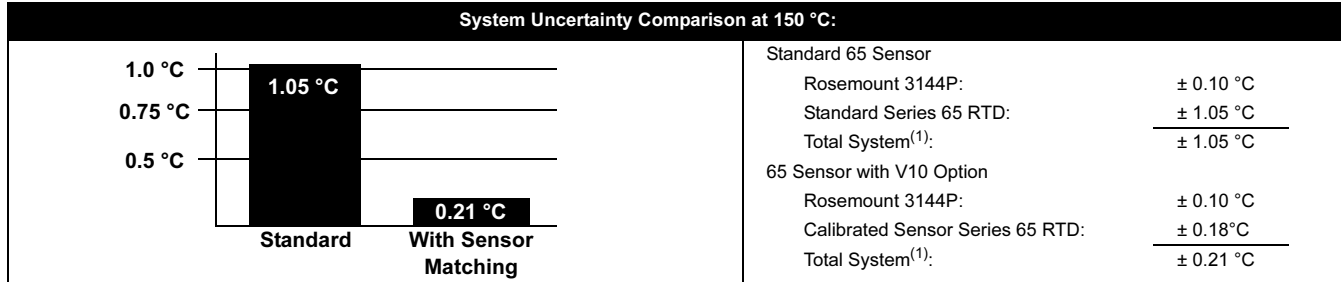

(1) Calculated using RSS statistical method:

$$\text{System accuracy} = \sqrt{(\text{Transmitter accuracy})^2 + (\text{Sensor accuracy})^2}$$

CALIBRATION

Sensor calibration may be required for input to quality systems, or for control system enhancement. More frequently, it is used to improve the overall temperature measurement performance by matching the sensor to a temperature transmitter. Sensor matching is available for RTD sensors used with Rosemount Smart transmitters where the inherent stability and repeatability of the RTD technology is well established.

Ordering Information

Use the formats presented below to order a calibrated Series 65 RTD. If you fail to specify all of the necessary calibration-related information when you place your order, Emerson will contact you for the information and your order may be delayed slightly.

Calibration Options

The X8 option calibrates the sensor to a customer-specific temperature range. The Callendar van Dusen, and A, B, and C-constants are supplied with a works certificate.

Option X8: Sensor Calibrated to a Customer-Specified Temperature Range (see Temperature Range)

When you order an RTD with the X8 option, the temperature range the sensor needs to be calibrated must be specified. Take note of the sensor temperature limits as shown below.

Typical Model Number	Model	Connection Head	Lead Wire Termination	Sensor Type	Extension Type	Extension Length	Thermowell Material	Immersion Length	Mounting Style	Additional Options
	0065	C	2	1	D	0135	D	0225	T12	X8

Calibrate from -10 to 120 °C

Option V: Sensor Calibration with Works Certificate

	Code	
	V10	V11
Temperature Range (°C)	- 50 to 450	0 to 100
Calibration Points (°C)	-50 0 100 450	0 50 100

Sensors and Accessories (Metric)

Sensor Assembly without Thermowell

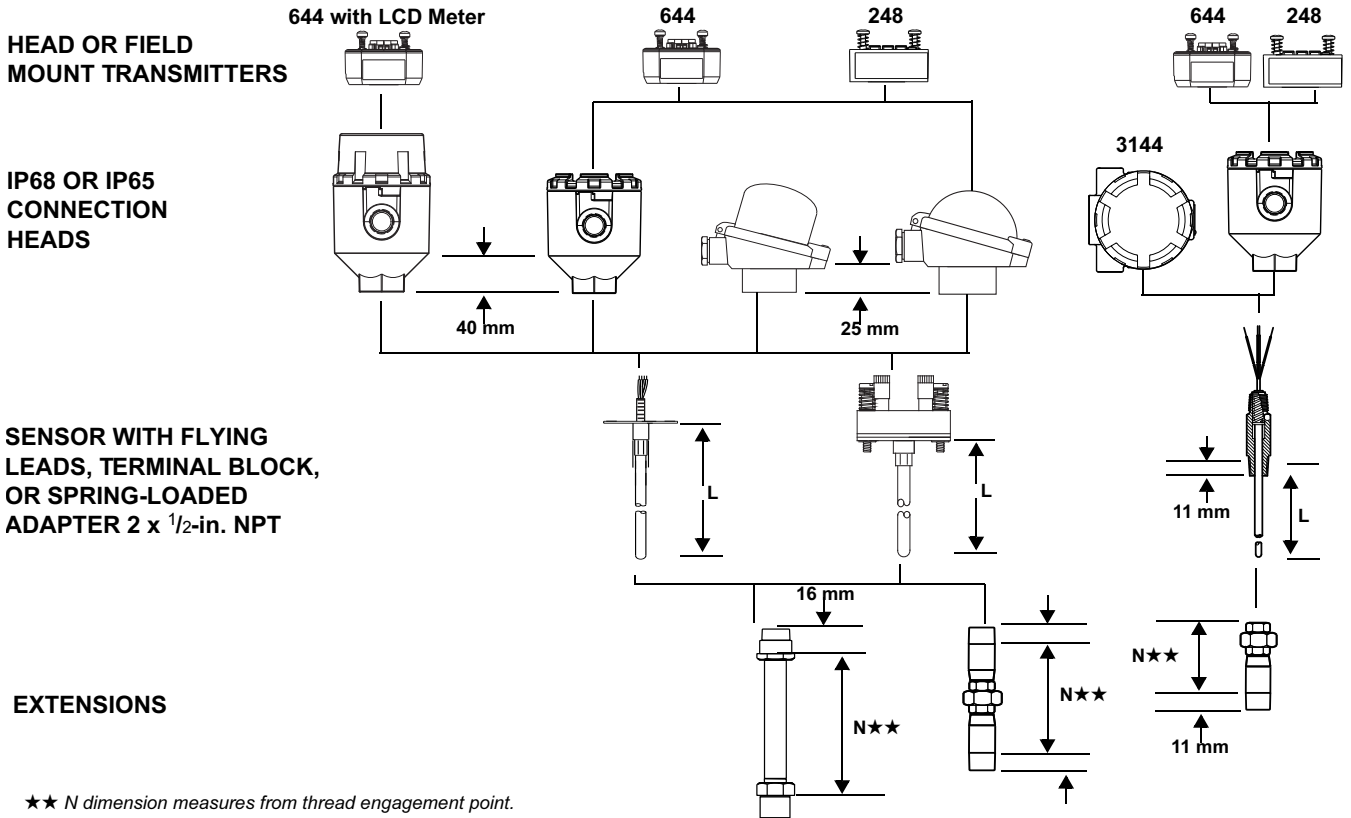

Series 65 RTD and Series 185 Thermocouple Dimensional Drawings				
ATEX/CENELEC EEx d Flameproof and SAA/FM Explosion-Proof Approved		Non-Approved		
Terminal Block	Flying Leads	Terminal Block	Flying Leads	1/2-ANPT Spring Loaded Adapter
41	41	41	41	
25	25	10	10	
8.00 + 0.00 - 0.05	8.00 + 0.00 - 0.05	8.00 + 0.00 - 0.05	8.00 + 0.00 - 0.05	11±2
L	L	L	L	L

Series	Sensor Diameter	Number of Leads	Lead Wire Length (Flying Leads)		Lead Wire Length (Spring Loaded)	
			Element 1	Element 2	Element 1	Element 2
65 Single Element	6.0	4	100	—	150	—
65 Dual Element	6.0	6	100	200	150	200
185 Single Element	6.0	2	100	—	150	—
185 Dual Element	6.0	4	100	200	150	200

Product Data Sheet

00813-0200-2654, Rev HA

February 2008

Sensors and Accessories (Metric)

ORDERING TABLES

Series 65 Platinum RTD and 185 Thermocouple Without Thermowell

Model	Product Description			
0065	Resistance Thermometer, Pt 100, Class B standard, suitable for transmitter mounting			
0185	Thermocouples, DIN EN 60584 (IEC 584), Class 1, suitable for transmitter mounting			
Code	Connection Head Material	IP Rating ⁽¹⁾	Conduit / Cable Entry	
C	Rosemount, aluminum – suitable for mounting 248, 644 transmitter inside	68	M20 x 1.5	
D	Rosemount, aluminum – suitable for mounting 248, 644 transmitter inside	68	1/2-in. NPT	
G	Rosemount, stainless steel – suitable for mounting 248, 644 transmitter inside	68	M20 x 1.5	
H	Rosemount, stainless steel – suitable for mounting 248, 644 transmitter inside	68	1/2-in. NPT	
J	GR-A/BL (BUZ), aluminum – suitable for mounting 248, 644 transmitter inside	65	M20 x 1.5 (with cable gland)	
L	TZ-A/BL (BUZH), aluminum – suitable for mounting 248, 644 transmitter inside	65	M20 x 1.5 (with cable gland)	
1	Rosemount, aluminum with LCD display cover	68	M20 x 1.5	
2	Rosemount, aluminum with LCD display cover	68	1/2-in. NPT	
N	No Connection head			
Code	Sensor Lead Wire Termination			
0	Flying leads – no springs on DIN plate			
2	Terminal block – DIN 43762			
3	Spring loaded adapter – 1/2-in. NPT – use with Extension Type codes J and N			
Code	Sensor Type	Temperature Range –valid for tolerance Class B Pt 100 only		
65 Only	1	RTD, single element, 4-wire	– 50 to 450 °C (–58 to 842 °F)	
	2	RTD, dual element, 3-wire	– 50 to 450 °C (–58 to 842 °F)	
	3	RTD, single element, 4-wire	–196 to 600 °C (–321 to 1112 °F)	
	4	RTD, dual element, 3-wire	–196 to 600 °C (–321 to 1112 °F)	
185 Only	03J1	Thermocouple, Type J, single element, ungrounded	– 40 to 750 °C (–40 to 1382 °F)	
	03K1	Thermocouple, Type K, single element, ungrounded	– 40 to 1000 °C (–40 to 1832 °F)	
	03N1	Thermocouple, Type N, single element, ungrounded	– 40 to 1000 °C (–40 to 1832 °F)	
	05J1	Thermocouple, Type J, dual element, isolated, ungrounded	– 40 to 750 °C (–40 to 1382 °F)	
	05K1	Thermocouple, Type K, dual element, isolated, ungrounded	– 40 to 1000 °C (–40 to 1832 °F)	
05N1	Thermocouple, Type N, dual element, isolated, ungrounded	– 40 to 1000 °C (–40 to 1832 °F)		
Code	Extension Type	Head Connection	Instrument Connection	Material
D	DIN – standard, 12 x 1.5	M24 x 1.5	1/2-in NPT	Stainless Steel (minimum length N = 35 mm)
T	DIN – standard, 12 x 1.5	M24 x 1.5	M18 x 1.5	Stainless Steel (minimum length N = 35 mm)
F	Nipple–Union–Nipple	1/2-in NPT	1/2-in NPT	Stainless Steel (minimum length N = 110 mm)
J	Nipple–Union (Sensor Lead Wire Terminal option code 3 only)	no head	1/2-in NPT	Stainless Steel (minimum length N = 80 mm)
N	No Extension (use when ordering the sensor alone, only available with Extension Length (N) code 0000)			
W	No Extension Head Connection	M24x1.5		
L	No Extension	1/2-in. NPT		
Code	Extension Length (N)			
0000	No extension – use with Extension Type code N			
0035	35 mm			
0080	80 mm – standard for Extension Type code J			
0110	110 mm – standard for Extension Type codes F and J			
0135	135 mm – standard for DIN Extension used with Rosemount Connection Head Material codes C, D, G, H, 1, and 2			
0150	150 mm – standard for DIN Extension used with Form B Connection Head Material codes J and L			
XXXX	Non-standard extension length – available from 35 to 500 mm			
Code	Thermowell Material			
N	No thermowell			
Code	Sensor Length (L)	Code	Sensor Length (L)	
0145	145 mm	0405	405 mm	
0205	205 mm	0435	435 mm	
0275	275 mm	0555	555 mm	
0315	315 mm	XXXX	Non-standard sensor length – available from min. 100 mm, max. 9999 mm	
0375	375 mm			
Code	Options			
Sensor Options (available with 65 only)				
A1	Single element Class A sensor from –50 to 450 °C (–58 to 842 °F)			
A2	Dual element Class A sensor from –50 to 450 °C (–58 to 842 °F)			
Hazardous Locations Certifications				
I1	EEx ia – ATEX/IBExU Intrinsic Safety Approval			
N1 ⁽²⁾⁽³⁾	EEx n – ATEX/CENELEC Type 'n' Approval			
E1 ⁽³⁾	EEx d – ATEX/CENELEC Flame-Proof Approval			
ND ⁽³⁾	ATEX Dust Ignition Proof			
E7 ⁽³⁾	SAA Flame Proof Approval			
E5 ⁽³⁾	EEx d – FM Explosion Proof Approval			
Accessories				
G1	External ground screw – only available with Rosemount Connection Head Material codes C, D, G, H, 1, and 2			
G3	Cover Chain – only available with Rosemount Connection Head Material codes C, D, G, and H,			
G6 ⁽⁴⁾	Aluminum Extension Ring for Dual Transmitter mounting in Connection Head – use with Rosemount Connection Head Material Codes C and D.			
TB	Terminal Block for use with sensor termination code 3 and Rosemount Heads C, D, G, and H			

Continued on Next Page

Sensors and Accessories (Metric)

Assemble To Option

XA⁽⁵⁾ Assemble sensor to specific temperature transmitter (hand tight, PTFE paste, fully wired) – valid with 144H, 248, 644, 3144 and 3244MV

Calibration Options (available with 65 only)

V10 Works certificate – sensor calibration from –50 to 450 °C (–58 to 842 °F) with A, B, C, and Callendar-van Dusen constants

V11 Works certificate – sensor calibration from 0 to 100 °C (–32 to 212 °F) with A, B, C, and Callendar-van Dusen constants

X8 Works certificate – sensor calibration over specified temperature range with A, B, C, and Callendar-van Dusen constants

Range

LT Special materials to meet extended temperature range of -51° C

Typical Model Number: 0065 C 2 3 D 0150 N 0315 A1

- (1) To maintain IP 68 rating, use a suitable cable gland on the conduit connection thread. All threads must be sealed with a suitable sealing tape.
- (2) For complete assemblies or as replacement sensor for N-series, component parts are not approved. If the transmitter is mounted in a connection head, the Sensor Lead Wire Termination code 0 (flying leads) is required.
- (3) Not available with Connection Head Material Codes J and L.
- (4) Not valid with E5, E7, ND or E1 Approval.
- (5) If ordering Assemble To Option XA with a transmitter, specify the same option on the transmitter model number.

Tubular Thermowell Sensor Assemblies

HEAD OR FIELD
 MOUNT TRANSMITTERS

IP68 OR IP65,
 CONNECTION
 HEADS

SENSOR WITH FLYING
 LEADS OR TERMINAL BLOCK

THREADED AND
 FLANGED TUBULAR
 THERMOWELLS

★★ For straight threading, *N* dimension references bottom of hex. For tapered threading, *N* dimension references thread engagement point (bottom of thread)

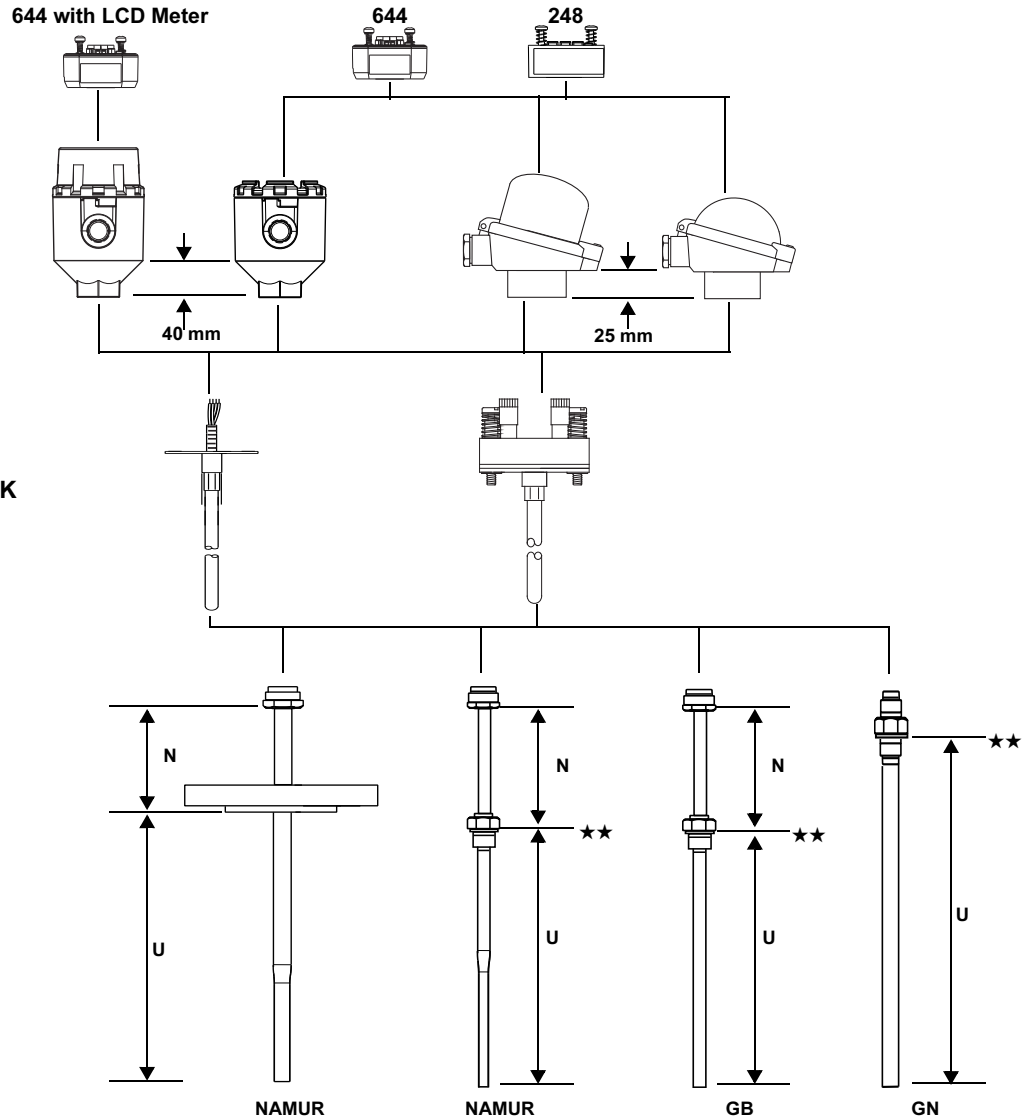

TABLE 3. Tubular Thermowell Ratings

Type	Dimensions	Process Connection	Max. Flow Velocity (m/s)		Immersion length (mm)	Max. Pressure (bar) ⁽¹⁾	At Temperature (°C)				
			Air	Water			0	100	200	300	400
GN, GB	9 x 1 mm 1.4571 (316 Ti)	Screw Socket G 1/2	25	3	160	50	48	44	40	36	
					250	40	40	40	40	36	
					400	18	18	18	18	18	
GN,	11 x 2 mm 1.4571 (316 Ti)	Screw Socket G1	40	5	160	100	95	92	88	80	
					250	50	50	50	50	50	
					400	18	18	18	18	18	
NAMUR	12 x 2.5 mm 1.4571 (316 Ti)	Screw Socket G1	40	5	160	100	100	100	100	100	
					220	100	100	100	78	78	
					280	100	100	100	55	55	

(1) For immersion "U" length (mm)

Sensors and Accessories (Metric)

Series 65 Platinum RTD and 185 Thermocouple With Tubular Thermowell

Model	Product Description		
0065	Resistance Thermometer, Pt 100, Class B standard, suitable for transmitter mounting		
0185	Thermocouples, DIN EN 60584 (IEC 584), Class 1, suitable for transmitter mounting		
Code	Connection Head Material	IP Rating ⁽¹⁾	Conduit / Cable Entry
C	Rosemount, aluminum – suitable for mounting 248, 644 transmitter inside	68	M20 x 1.5
D	Rosemount, aluminum – suitable for mounting 248, 644 transmitter inside	68	1/2-in. NPT
G	Rosemount, stainless steel – suitable for mounting 248, 644 transmitter inside	68	M20 x 1.5
H	Rosemount, stainless steel – suitable for mounting 248, 644 transmitter inside	68	1/2-in. NPT
J	GR –A/BL (BUZ), aluminum – suitable for mounting 248, 644 transmitter inside	65	M20 x 1.5 (with cable gland)
L	TZ–A/BL (BUZH), aluminum – suitable for mounting 248, 644 transmitter inside	65	M20 x 1.5 (with cable gland)
1	Rosemount, aluminum with LCD display cover	68	M20 x 1.5
2	Rosemount, aluminum with LCD display cover	68	1/2-in. NPT
Code	Sensor Lead Wire Termination		
0	Flying leads – no springs on DIN plate		
2	Terminal block – DIN 43762		
Code	Sensor Type	Temperature Range –valid for tolerance Class B Pt 100 only	
65 Only	1	RTD, single element, 4-wire	– 50 to 450 °C (–58 to 842 °F)
	2	RTD, dual element, 3-wire	– 50 to 450 °C (–58 to 842 °F)
	3	RTD, single element, 4-wire	–196 to 600 °C (–321 to 1112 °F)
	4	RTD, dual element, 3-wire	–196 to 600 °C (–321 to 1112 °F)
185 Only	03J1	Thermocouple, Type J, single element, ungrounded	– 40 to 750 °C (–40 to 1382 °F)
	03K1	Thermocouple, Type K, single element, ungrounded	– 40 to 1000 °C (–40 to 1832 °F)
	03N1	Thermocouple, Type N, single element, ungrounded	– 40 to 1000 °C (–40 to 1832 °F)
	05J1	Thermocouple, Type J, dual element, isolated, ungrounded	– 40 to 750 °C (–40 to 1382 °F)
	05K1	Thermocouple, Type K, dual element, isolated, ungrounded	– 40 to 1000 °C (–40 to 1832 °F)
	05N1	Thermocouple, Type N, dual element, isolated, ungrounded	– 40 to 1000 °C (–40 to 1832 °F)
Code	Extension Type		
Y	Tubular, no extension – form GN		
Z	Tubular, with extension – form GB, NAMUR		
Code	Extension Length (N)	Code	Extension Length (N)
0000	No extension – use with Extension Type code Y		
0050	50 mm	0130	130 mm
0065	65 mm	0200	200 mm
0105	105 mm	0250	250 mm
0115	115 mm	XXXX	Non-standard extension length – available from 35 to 500 mm
Code	Thermowell Material	Maximum Temperature Range	
D ⁽²⁾	1.4404 (AISI 316L)	Ratings, see Table 3 on page Temperature-11 (standard material for Asia)	
Y	1.4571 (AISI 316Ti)	Ratings, see Table 3 on page Temperature-11 (standard material for Europe, Middle East, Africa)	
Code	Immersion Length (U)	Code	Immersion Length (U)
0050	50 mm	0225	225 mm
0075	75 mm	0250	250 mm
0100	100 mm	0280	280 mm
0115	115 mm	0285	285 mm
0130	130 mm	0300	300 mm
0150	150 mm	0345	345 mm
0160	160 mm	0400	400 mm
0200	200 mm	XXXX	Non-standard immersion length – available from 50 to 2500 mm
0220	220 mm		
Code	Mounting Style	Process Connections	Stem Style
G02	Thread, tapered	R 1/2-in. (1/2-in. BSPT)	Stepped, NAMUR ⁽³⁾
G04	Thread, tapered	R 3/4-in. (3/4-in. BSPT)	Stepped, NAMUR ⁽³⁾
G06	Thread, tapered	R 1-in. (1-in. BSPT)	Stepped, NAMUR ⁽³⁾
G13	Thread, parallel	M27 x 2	Stepped, NAMUR ⁽³⁾
G20	Thread, parallel	G 1/2-in. (1/2-in. BSPF)	Stepped, NAMUR ⁽³⁾
G22	Thread, parallel	G 3/4-in. (3/4-in. BSPF)	Stepped, NAMUR ⁽³⁾
G24	Thread, parallel	G 1-in. (1-in. BSPF)	Stepped, NAMUR ⁽³⁾
G91	Thread, parallel	M20 x 1.5	Stepped, NAMUR ⁽³⁾
G31	Thread, parallel	M33 x 2	Stepped, NAMUR ⁽³⁾
G38	Thread, tapered	1/2-in. NPT	Stepped, NAMUR ⁽³⁾
G40	Thread, tapered	3/4-in. NPT	Stepped, NAMUR ⁽³⁾
G42	Thread, tapered	1-in. NPT	Stepped, NAMUR ⁽³⁾
G52	Thread, parallel	G 1/2-in. (1/2-in. BSPF)	Straight, GN, D. 9 x 1 mm ⁽⁴⁾
G92	Thread, parallel	M20 x 1.5	Straight, GN, D. 9 x 1 mm ⁽⁴⁾
G63	Thread, parallel	G 1/2-in. (1/2-in. BSPF)	Straight, GN, D. 11 x 2 mm ⁽⁴⁾
G94	Thread, parallel	M20 x 1.5	Straight, GN, D. 11 x 2 mm ⁽⁴⁾
G72	Thread, parallel	G 1/2-in. (1/2-in. BSPF)	Straight, GB, D. 9 x 1 mm ⁽⁴⁾
G95	Thread, parallel	M20 x 1.5	Straight, GB, D. 9 x 1 mm ⁽⁴⁾
L02	Flange, RF	1-in. 150 lbs	Stepped, NAMUR ⁽³⁾
L08	Flange, RF	1.5-in. 150 lbs	Stepped, NAMUR ⁽³⁾
L14	Flange, RF	2-in. 150 lbs	Stepped, NAMUR ⁽³⁾

Continued on Next Page

Product Data Sheet

00813-0200-2654, Rev HA

February 2008

Sensors and Accessories (Metric)

Code	Mounting Style (Continued)	Process Connections	Stem Style
L20	Flange, RF	1-in. 300 lbs	Stepped, NAMUR ⁽³⁾
L26	Flange, RF	1.5-in. 300 lbs	Stepped, NAMUR ⁽³⁾
L32	Flange, RF	2-in. 300 lbs	Stepped, NAMUR ⁽³⁾
H02	Flange, Form B1 according to EN 1092-1	DN 25 PN 16	Stepped, NAMUR ⁽³⁾
H08	Flange, Form B1 according to EN 1092-1	DN 25 PN 25/40	Stepped, NAMUR ⁽³⁾
H14	Flange, Form B1 according to EN 1092-1	DN 40 PN 16	Stepped, NAMUR ⁽³⁾
H20	Flange, Form B1 according to EN 1092-1	DN 40 PN 25/40	Stepped, NAMUR ⁽³⁾
H26	Flange, Form B1 according to EN 1092-1	DN 50 PN 40	Stepped, NAMUR ⁽³⁾
Code	Options		
Sensor Options (available with 65 only)			
A1	Single element Class A sensor from -50 to 450 °C (-58 to 842 °F)		
A2	Dual element Class A sensor from -50 to 450 °C (-58 to 842 °F)		
Hazardous Locations Certifications			
I1	EEx ia – ATEX / IBExU Intrinsic Safety Approval		
N1 ⁽⁵⁾⁽⁶⁾	EEx n – ATEX/CENELEC Type 'n' Approval		
E1 ⁽⁶⁾	EEx d – ATEX/CENELEC Flame Proof Approval		
ND ⁽⁶⁾	ATEX Dust Ignition Proof		
E7 ⁽⁶⁾	SAA Flame Proof Approval		
E5 ⁽⁶⁾	EEx d – FM Explosion Proof Approval (consult factory for availability)		
Accessories			
G1	External ground screws – only available with Rosemount Connection Head Material codes C, D, G, H, 1, and 2		
G3	Cover Chain – only available with Rosemount Connection Head Material codes C, D, G, and H,		
G6 ⁽⁷⁾	Aluminum Extension Ring for Dual Transmitter mounting in Connection Head – use with Rosemount Connection Head Material Codes C and D.		
Thermowell Options			
Q8	Thermowell material certification, DIN EN 10204 3.1		
R01 ⁽⁸⁾	Thermowell External Pressure Testing		
R03	Thermowell Dye Penetration Testing		
R04	Thermowell Special Cleaning		
Assemble To Options			
XA ⁽⁹⁾	Assemble sensor to specific temperature transmitter (hand tight, PTFE paste, fully wired) – valid with 144H, 248, 644, 3144 and 3244MV		
Calibration options (available with 65 only)			
V10	Works certificate – sensor calibration from -50 to 450 °C (-58 to 842 °F) with A, B, C, and Callendar-van Dusen constants		
V11	Works certificate – sensor calibration from 0 to 100 °C (-32 to 212 °F) with A, B, C, and Callendar-van Dusen constants		
X8	Works certificate – sensor calibration over specified temperature range with A, B, C, and Callendar-van Dusen constants		
Range			
LT	Special materials to meet extended temperature range of -51 °C		
Typical Model Number: 0065 L 2 1 Z 0115 Y 0375 G20 XA			

- (1) To maintain IP 68 rating, use a suitable cable gland on the conduit connection thread. All threads must be sealed with a suitable sealing tape.
- (2) Process thread or process flange to be 316L material with a stem material of 316Ti. Not NAMUR compliant.
- (3) NAMUR compliance only applicable with 316Ti material code "Y". Minimum immersion length of 115 mm. For u < 115 mm, use straight thermowell, 8 mm Diameter.
- (4) Not available with Thermowell Material code D.
- (5) For complete assemblies or as replacement sensor for type N-series, component parts are not approved. If the transmitter is mounted in a connection head, the Sensor Lead Wire Termination code 0 (flying leads) is requested.
- (6) Not available with Connection Head Material codes J and L.
- (7) Not valid with E5, E7, ND, or E1 Approval.
- (8) Not available with welded connection.
- (9) If ordering Assemble To Option XA with a transmitter, specify the same option on the transmitter model number.

Sensors and Accessories (Metric)

Barstock Thermowell Sensor Assemblies

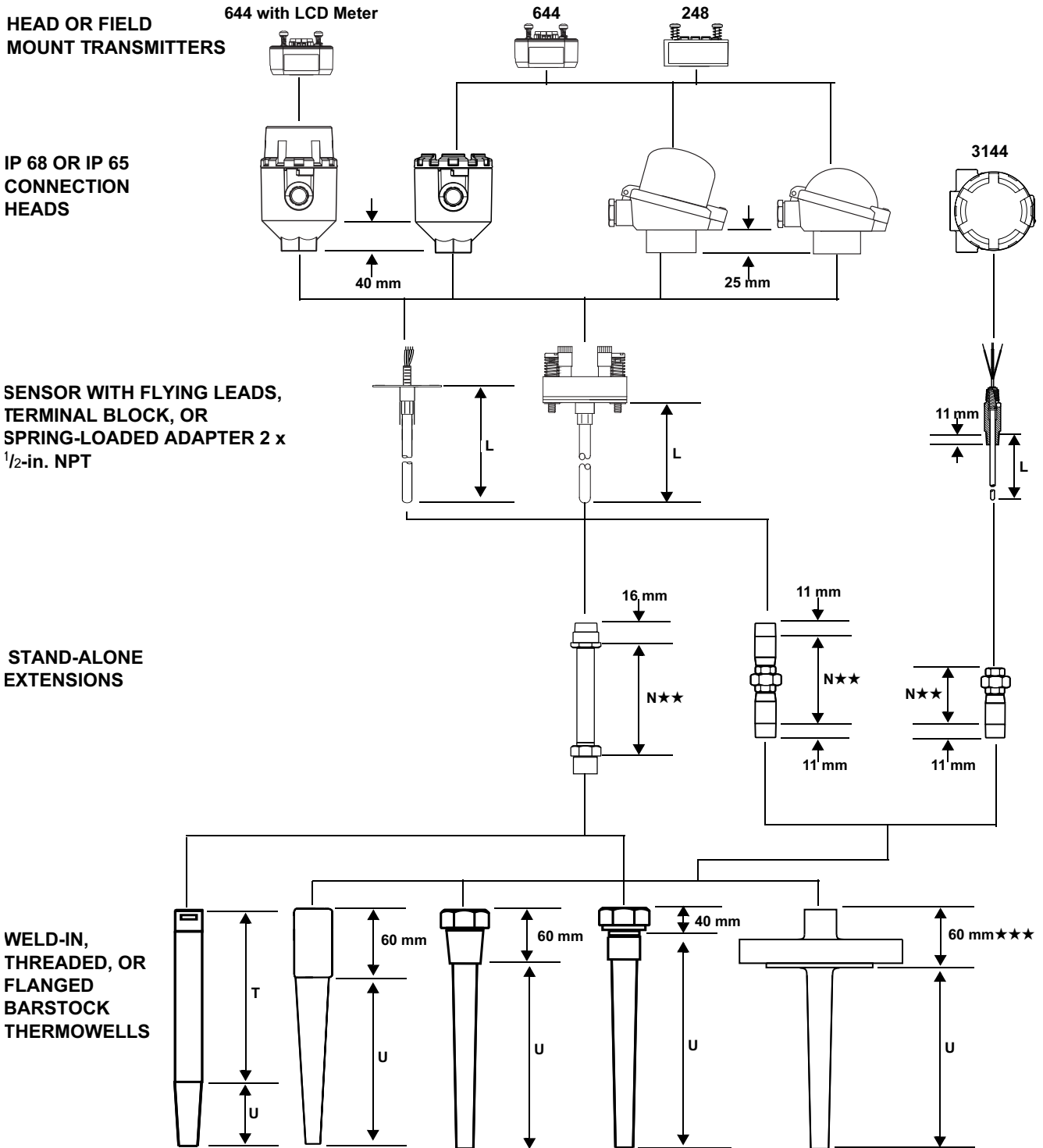

** N dimension measures from thread engagement point.
 *** This dimension is 80 mm for 1500# and 2500# flanges.

Product Data Sheet

00813-0200-2654, Rev HA

February 2008

Sensors and Accessories (Metric)

Series 65 Platinum RTD and 185 Thermocouple With Barstock Thermowell

Model	Product Description			
0065	Resistance Thermometer, Pt 100, Class B standard, suitable for transmitter mounting			
0185	Thermocouples, DIN EN 60584 (IEC 584), Class 1, suitable for transmitter mounting			
Code	Connection Head Material	IP Rating ⁽¹⁾	Conduit / Cable Entry	
C	Rosemount, aluminum – suitable for mounting 248, 644 transmitter inside	68	M20 x 1.5	
D	Rosemount, aluminum – suitable for mounting 248, 644 transmitter inside	68	1/2-in. NPT (cable entry)	
G	Rosemount, stainless steel – suitable for mounting 248, 644 transmitter inside	68	M20 x 1.5 (cable entry)	
H	Rosemount, stainless steel – suitable for mounting 248, 644 transmitter inside	68	1/2-in. NPT (cable entry)	
J	GR –A/BL (BUZ), aluminum – suitable for mounting 248, 644 transmitter inside	65	M20 x 1.5 (with cable gland)	
L	TZ–A/BL (BUZH), aluminum – suitable for mounting 248, 644 transmitter inside	65	M20 x 1.5 (with cable gland)	
1	Rosemount, aluminum with LCD display cover	68	M20 x 1.5	
2	Rosemount, aluminum with LCD display cover	68	1/2-in. NPT	
N	No Connection head			
Code	Sensor Lead Wire Termination			
0	Flying leads – no springs on DIN plate			
2	Terminal block – DIN 43762			
3	Spring loaded adapter – 1/2-in. NPT – use with Extension Type codes J and N			
Code	Sensor Type	Temperature Range –valid for tolerance Class B Pt 100 only		
65 Only	1	RTD, single element, 4-wire	– 50 to 450 °C (–58 to 842 °F)	
	2	RTD, dual element, 3-wire	– 50 to 450 °C (–58 to 842 °F)	
	3	RTD, single element, 4-wire	–196 to 600 °C (–321 to 1112 °F)	
	4	RTD, dual element, 3-wire	–196 to 600 °C (–321 to 1112 °F)	
185 Only	03J1	Thermocouple, Type J, single element, ungrounded	– 40 to 750 °C (–40 to 1382 °F)	
	03K1	Thermocouple, Type K, single element, ungrounded	– 40 to 1000 °C (–40 to 1832 °F)	
	03N1	Thermocouple, Type N, single element, ungrounded	– 40 to 1000 °C (–40 to 1832 °F)	
	05J1	Thermocouple, Type J, dual element, isolated, ungrounded	– 40 to 750 °C (–40 to 1382 °F)	
	05K1	Thermocouple, Type K, dual element, isolated, ungrounded	– 40 to 1000 °C (–40 to 1832 °F)	
05N1	Thermocouple, Type N, dual element, isolated, ungrounded	– 40 to 1000 °C (–40 to 1832 °F)		
Code	Extension Type	Head Connection	Instrument Connection	Material
D	DIN – standard, 12 x 1.5	M24 x 1.5	1/2-in NPT	Stainless Steel (minimum length N = 35 mm)
T ⁽²⁾	DIN – standard, 12 x 1.5	M24 x 1.5	M18 x 1.5	Stainless Steel (minimum length N = 35 mm)
F	Nipple–Union–Nipple	1/2-in NPT	1/2-in NPT	Stainless Steel (minimum length N = 110 mm)
J	Nipple–Union (Sensor Lead Wire Terminal option code 3 only)	(No Head)	1/2-in NPT	Stainless Steel (minimum length N = 80 mm)
N	No Extension (only available with Extension length (N) code 0000)			
Code	Extension Length (N)			
0000	No extension – use with Extension Type code N			
0035	35 mm			
0080	80 mm– standard for Extension Type code J			
0110	110 mm – standard for Extension Type codes F and J			
0135	135 mm – standard for DIN Extension used with Rosemount Connection Head Material codes C, D, G, H, 1, and 2			
0150	150 mm – standard for DIN Extension used with Form B Connection Head Material codes J and L			
XXXX	Non-standard extension length – available from 35 to 500 mm			
Code	Thermowell Material			
D	1.4404 (AISI 316L)			
Y	1.4571 (AISI 316Ti)			
Code	Immersion Length (U)			
0065	65 mm			
0075	75 mm			
0115	115 mm			
0125	125 mm			
0150	150 mm			
0225	225 mm			
0300	300 mm			
0450	450 mm			
XXXX	Non-standard immersion length – available from 80 to 1000 mm in 5mm increments			
Code	Mounting Style	Process Connections	Stem Style	
T08	Threaded	R 1/2-in. (1/2-in. BSPT)	Tapered	
T10	Threaded	R 3/4-in. (3/4-in. BSPT)	Tapered	
T12	Threaded	R 1-in. (1-in. BSPT)	Tapered	
T26	Threaded	G 1/2-in. (1/2-in. BSPF)	Tapered	
T28	Threaded	G 3/4-in. (3/4-in. BSPF)	Tapered	
T30	Threaded	G 1-in. (1-in. BSPF)	Tapered	
T44	Threaded	1/2-in. NPT	Tapered	
T46	Threaded	3/4-in. NPT	Tapered	
T48	Threaded	1-in. NPT	Tapered	
T93	Threaded	M27 x 2	Tapered	
T95	Threaded	M33 x 2	Tapered	
T98	Threaded	M20 x 1.5	Tapered	
F04	Flanged, RF	1-in. 150 lbs	Tapered	
F10	Flanged, RF	1.5-in. 150 lbs	Tapered	
F16	Flanged, RF	2-in. 150 lbs	Tapered	

Continued on Next Page

Sensors and Accessories (Metric)

Code	Mounting Style (Continued)	Process Connections	Stem Style
F22	Flanged, RF	1-in. 300 lbs	Tapered
F28	Flanged, RF	1.5-in. 300 lbs	Tapered
F34	Flanged, RF	2-in. 300 lbs	Tapered
F40	Flanged, RF	1-in. 600 lbs	Tapered
F46	Flanged, RF	1.5-in. 600 lbs	Tapered
F52	Flanged, RF	2-in. 600 lbs	Tapered
F58 ⁽³⁾	Flanged, RF	1-in. 900/1500 lbs	Tapered
F64 ⁽³⁾	Flanged, RF	1.5-in. 900/1500 lbs	Tapered
F70 ⁽³⁾	Flanged, RF	2-in. 900/1500 lbs	Tapered
F82	Flanged, RF	1.5 in., 2500 lbs.	Tapered
F88	Flanged, RF	2 in. 2500 lbs.	Tapered
D04	Flange, Form B1 according to EN 1092-1	DN 25 PN 16	Tapered
D10	Flange, Form B1 according to EN 1092-1	DN 25 PN 25/40	Tapered
D16	Flange, Form B1 according to EN 1092-1	DN 40 PN 16	Tapered
D22	Flange, Form B1 according to EN 1092-1	DN 40 PN 25/40	Tapered
D28	Flange, Form B1 according to EN 1092-1	DN 50 PN 40	Tapered
W10	Welded	¾-in. pipe	Tapered
W12	Welded	1-in. pipe	Tapered
W14	Welded	1¼-in. pipe	Tapered
W16	Welded	1½-in. pipe	Tapered
E01	D1 welded	24h7	Tapered
E02	D2 welded	24h7	Tapered
E04	D4 welded	24h7	Tapered
E05	D5 welded	24h7	Tapered
Code	Options		
Sensor Options (available with 65 only)			
A1	Single element Class A sensor from -50 to 450 °C (-58 to 842 °F)		
A2	Dual element Class A sensor from -50 to 450 °C (-58 to 842 °F)		
Hazardous Locations Certifications			
I1	EEx ia – ATEX/IBExU Intrinsic Safety Approval		
N1 ⁽⁴⁾⁽⁵⁾	EEx n – ATEX/CENELEC Type 'n' Approval		
E1 ⁽⁵⁾	EEx d – ATEX/CENELEC Flame-Proof Approval		
ND ⁽⁵⁾	ATEX Dust Ignition Proof		
E7 ⁽⁵⁾	SAA Flame Proof Approval		
E5 ⁽⁵⁾	EEx d – FM Explosion Proof Approval (consult factory for availability)		
Accessories			
G1	External ground screws – only available with Rosemount Connection Head Material codes C, D, G, H, 1, and 2		
G3	Cover Chain – only available with Rosemount Connection Head Material codes C, D, G, and H,		
G6 ⁽⁶⁾	Aluminum Extension Ring for Dual Transmitter mounting in Connection Head – use with Rosemount Connection Head Material Codes C and D.		
TB	Terminal Block for use with sensor termination code 3 and Connection Heads C, D, G, and H		
Thermowell Options			
Q8	Thermowell material certification, DIN EN 10204 3.1		
R01	Thermowell External Pressure Testing	Flanged and Threaded thermowell only	
R22	Thermowell Internal Pressure Testing		
R03	Thermowell Dye Penetration Testing		
R04	Thermowell Special Cleaning		
R05 ⁽⁷⁾	Thermowell NACE Heat Treatment Approval		
R06	Stainless Steel Plug and Chain		
R07	Full Penetration Weld - for flanged thermowells only		
R16	Ring Joint; Flange face to ANSI B 16.5		
R21	Wake Frequency – Thermowell Strength Calculation		
Assemble To Options			
XA ⁽⁸⁾	Assemble sensor to specific temperature transmitter (hand tight, PTFE paste, fully wired) – valid with 144H, 248H, 644H, 3144 and 3244MV		
Calibration Options (available with 65 only)			
V10	Works certificate – sensor calibration from -50 to 450 °C (-58 to 842 °F) with A, B, C, and Callendar-van Dusen constants		
V11	Works certificate – sensor calibration from 0 to 100 °C (-32 to 212 °F) with A, B, C, and Callendar-van Dusen constants		
X8	Works certificate – sensor calibration over specified temperature range with A, B, C, and Callendar-van Dusen constants		
Range			
LT	Special materials to meet extended temperature range of -51 °C		
Typical Model Number: 0065 G 2 2 D 0135 D 0225 F70 Q8 R01 R07			

(1) To maintain IP 68 rating, use a suitable cable gland on the conduit connection thread. All threads must be sealed with a suitable sealing tape.

(2) Only available with Thermowell Mounting Style codes E01, E02, E04, and E05.

(3) Standard T-length is 80 mm, full penetration option R07 must be ordered.

(4) For complete assemblies or as replacement sensor for type N-series, component parts are not approved. If the transmitter is mounted in a connection head, the Sensor Lead Wire Termination code 0 (flying leads) is requested.

(5) Not available with Connection Head Material codes J and L.

(6) Not valid with E5, E7, ND, or E1 Approval

(7) Valid for thermowell material code D AISI 316L (1.4404) only.

(8) If ordering Assemble To Option XA with a transmitter, specify the same option on the transmitter model number.

Accessories

TABLE 4. Connection Head

Part Number	Model/Material	IP Rating	Conduit Connection	Process Connection
00644-4410-0011	Rosemount, Aluminium	68	1/2-inch NPT	1/2-inch NPT
00644-4410-0013	Rosemount, Aluminium	68	1/2-inch NPT	M24 x 1.5
00644-4410-0021	Rosemount, Aluminium	68	M20 x 1.5	1/2-inch NPT
00644-4410-0023	Rosemount, Aluminium	68	M20 x 1.5	M24 x 1.5
00644-4410-0111	Rosemount, Aluminium with LCD Display Cover	68	1/2-inch NPT	1/2-inch NPT
00644-4410-0113	Rosemount, Aluminium with LCD Display Cover	68	1/2-inch NPT	M24 x 1.5
00644-4410-0121	Rosemount, Aluminium with LCD Display Cover	68	M20 x 1.5	1/2-inch NPT
00644-4410-0123	Rosemount, Aluminium with LCD Display Cover	68	M20 x 1.5	M24 x 1.5
00644-4411-0011	Rosemount, Stainless Steel	68	1/2-inch NPT	1/2-inch NPT
00644-4411-0013	Rosemount, Stainless Steel	68	1/2-inch NPT	M24 x 1.5
00644-4411-0021	Rosemount, Stainless Steel	68	M20 x 1.5	1/2-inch NPT
00644-4411-0023	Rosemount, Stainless Steel	68	M20 x 1.5	M24 x 1.5
00644-4196-0023	GR-A/BL (BUZ), Aluminium	65	M20 x 1.5	M24 x 1.5
00644-4197-0023	TZ-A/BL (BUZH), Aluminium	65	M20 x 1.5	M24 x 1.5

FIGURE 5. Connection Head Dimensional Drawing

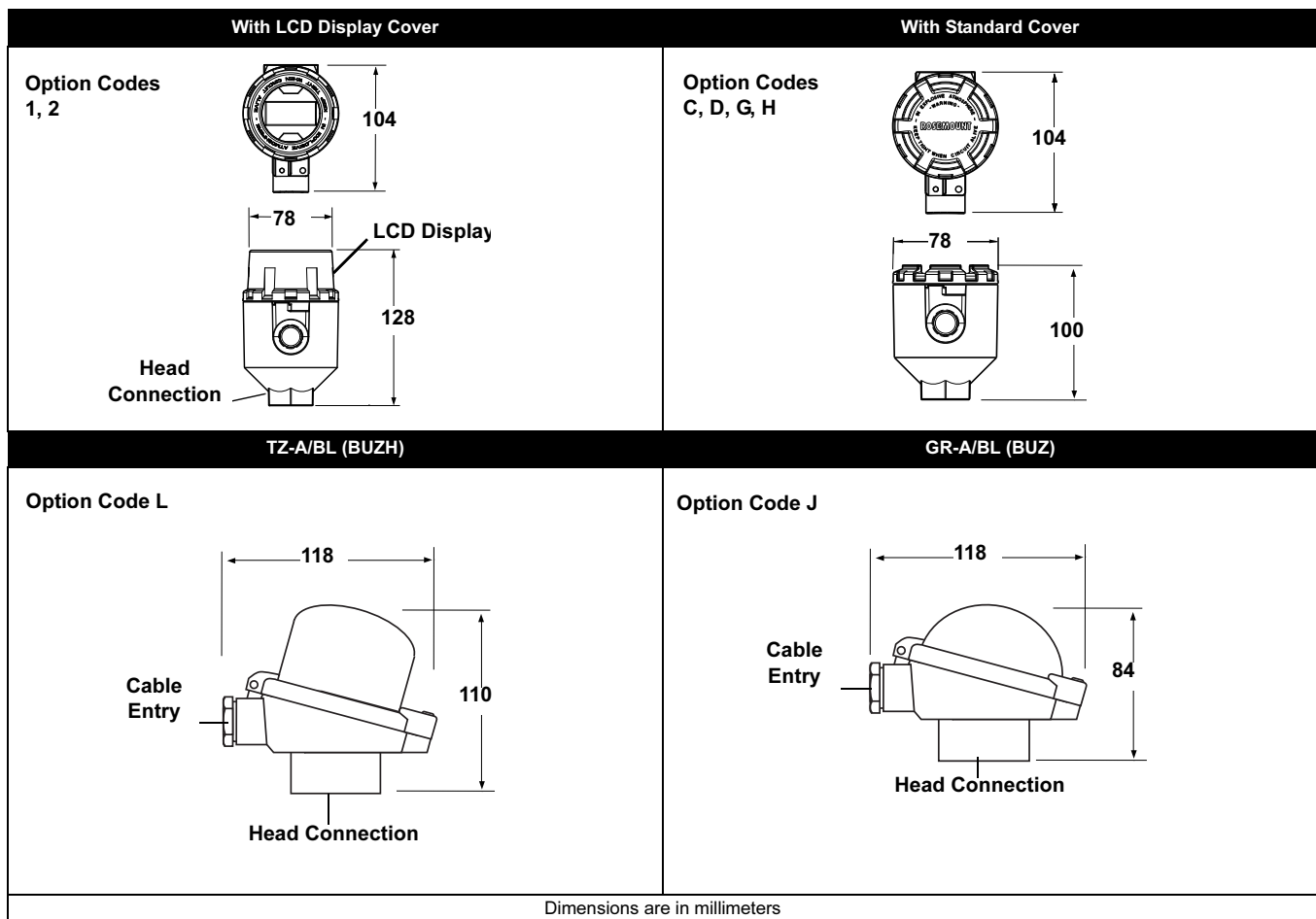

Sensors and Accessories (Metric)

Series 96 Barstock Thermowells

U = Immersion Length

D = Stem Diameter

TL = Total Length

T = Lagging Length

Dimensions in millimeters

Flanged Barstock Thermowell – Tapered

Flange Size	D	d	T
1-in. 150 – 1500 lbs, DN 25	19	12.5	60
1 1/2 to 2-in. 150 – 600 lbs, DN40 - 50	26.5	18	60
1.5 to 2-in. 900/1500	26.5	18	80

Note: Flanged thermowells generally conform to the specifications of ASME B 16.5 (ANSI) and DIN EN 1092-1.

Threaded Barstock Thermowell – Parallel Thread

Parallel Thread Size	D	D1	d
1/2-in. BSPF (G ^{1/2}); M20 x 1.5	17	26	12.5
3/4-in. BSPF (G ^{3/4})	19	32	12.5
1-in. BSPF (G1)	26.5	39	18
M24 x 1.5	19	29	12.5

Threaded Barstock Thermowell – Tapered Thread

Tapered Thread Size	D	d
1/2-in. NPT ; M20 x 1.5	17	12.5
3/4-in. NPT	19	12.5
1-in. NPT	26.5	18

--
 U = Immersion Length D = Stem Diameter TL = Total Length T = Lagging Length

Dimensions in millimeters

Weld-in Barstock Thermowell (codes W10, W12, W14, W16)

Socket Size	S	D	d
3/4-in.	26.7	19.0	12.5
1-in.	33.4	19.0	12.5
1 1/4-in.	42.2	19.0	12.5
1 1/2-in.	48.3	19.0	12.5

Weld-in Barstock Thermowell (codes E01, E02, E04, E05)

Previous DIN Form	D1	D2	D4	D5	d
TL	140	200	200	260	12.5
U	65	125	65	125	12.5
T	75	75	135	135	12.5

Sensors and Accessories (Metric)

Series 96 Barstock Thermowell

Model	Product Description		
0096	Barstock Thermowell		
Code	Thermowell Material ⁽¹⁾		
D	1.4404 (AISI 316L)		
Y	1.4571 (AISI 316Ti)		
Code	Immersion Length (U)		
0065	65 mm – standard length for weld-in thermowells, E01 and E04		
0075	75 mm		
0115	115 mm		
0125	125 mm – standard length for weld-in thermowells, E02 and E05		
0150	150 mm		
0225	225 mm		
0300	300 mm		
0450	450 mm		
XXXX	Non-standard immersion length		
Code	Mounting Style	Process Connections	Stem Style
T08	Thread	R 1/2-in. (1/2-in. BSPT)	Tapered
T10	Thread	R 3/4-in. (3/4-in. BSPT)	Tapered
T12	Thread	R 1-in. (1-in. BSPT)	Tapered
T26	Thread	G 1/2-in. (1/2-in. BSPF)	Tapered
T28	Thread	G 3/4-in. (3/4-in. BSPF)	Tapered
T30	Thread	G 1-in. (1-in. BSPF)	Tapered
T44	Thread	1/2-in. NPT	Tapered
T46	Thread	3/4-in. NPT	Tapered
T48	Thread	1-in. NPT	Tapered
T93	Thread	M27 x 2	Tapered
T95	Thread	M33 x 2	Tapered
T98	Thread	M20 x 1.5	Tapered
F04	Flange, RF	1-in. 150 lbs	Tapered
F10	Flange, RF	1.5-in. 150 lbs	Tapered
F16	Flange, RF	2-in. 150 lbs	Tapered
F22	Flange, RF	1-in. 300 lbs	Tapered
F28	Flange, RF	1.5-in. 300 lbs	Tapered
F34	Flange, RF	2-in. 300 lbs	Tapered
F40	Flange, RF	1-in. 600 lbs	Tapered
F46	Flange, RF	1.5-in. 600 lbs	Tapered
F52	Flange, RF	2-in. 600 lbs	Tapered
F58 ⁽²⁾	Flanged, RF	1-in. 900/1500 lbs	Tapered
F64 ⁽²⁾	Flanged, RF	1.5-in. 900/1500 lbs	Tapered
F70 ⁽²⁾	Flanged, RF	2-in. 900/1500 lbs	Tapered
F82	Flanged, RF	1.5 in 2500 lbs	Tapered
F88	Flanged, RF	2 in. 2500 lbs	Tapered
D04	Flange, Form B1 according to EN 1092-1	DN 25 PN 16	Tapered
D10	Flange, Form B1 according to EN 1092-1	DN 25 PN 25/40	Tapered
D16	Flange, Form B1 according to EN 1092-1	DN 40 PN 16	Tapered
D22	Flange, Form B1 according to EN 1092-1	DN 40 PN 25/40	Tapered
D28	Flange, Form B1 according to EN 1092-1	DN 50 PN 40	Tapered
W10	Welded	3/4-in. pipe	Tapered
W12	Welded	1-in. pipe	Tapered
W14	Welded	1 1/4-in. pipe	Tapered
W16	Welded	1 1/2-in. pipe	Tapered
E01	D1 welded, DIN	24h7	Tapered
E02	D2 welded, DIN	24h7	Tapered
E04	D4 welded, DIN	24h7	Tapered
E05	D5 welded, DIN	24h7	Tapered
Code	Lagging Length		
T040	40 mm – valid for Mounting style codes T26, T28, T30, T93, T95, and T98		
T060	60 mm		
T075	75 mm – valid for weld-in thermowells codes E01 and E02		
T080	80 mm – valid for flanged thermowells codes F58, F64, F70		
T135	135 mm – valid for weld-in thermowells codes E04 and E05		
Code	Instrument Connection Thread Type		
A	M24 x 1.5		
D	1/2-in. NPT		
T	M18 x 1.5 – valid for weld-in thermowells codes E01, E02, E04, and E05		

Continued on Next Page

Product Data Sheet

00813-0200-2654, Rev HA

February 2008

Sensors and Accessories (Metric)

Code	Options
Thermowell Options	
Q8	Thermowell material certification, DIN EN 10204 3.1B
R01	Thermowell External Pressure Testing (flanged thermowells only)
R22	Thermowell Internal Pressure Testing
R03	Thermowell Dye Penetration Testing
R04	Thermowell Special Cleaning
R05 ⁽³⁾	Thermowell NACE Heat Treatment Approval
R06	Stainless Steel Plug and Chain
R07	Full Penetration Weld - for flanged thermowells only
R16	Ring Joint; Flange face to ANSI B 16.5
R21	Wake Frequency – Thermowell Strength Calculation
Typical Model Number: 0096 D 0300 F04 T060 D Q8 R01	

(1) Additional materials are available upon request.

(2) Standard T-length is 80 mm, full penetration option R07 must be ordered.

(3) Not available with Thermowell Material code Y.

Sensors and Accessories (Metric)

Thermowell Strength Calculation

Pressure and Flow Vibration

The strength of a thermowell depends on several parameters relating thermowell construction to the installation environment. For most industrial applications, standard Rosemount thermowells provide the necessary strength if the material, style, and length are correct for the application. The proper selection of a thermowell depends on fluid type, temperature, pressure, and fluid velocity. Most thermowell failures are caused by vibration that is induced by fluid flow.

Emerson has a design system for the correct selection of thermowells. This selection service is available for a nominal charge, and to take advantage of this service, complete and return the Thermowell Strength Calculation to your local Emerson Process Management representative.

Emerson includes three possible failure modes in conjunction with thermowell analysis:

Flow-Induced Vibration

Fluid flow past a thermowell causes vortices to be shed from the well at a wake frequency proportional to the flow velocity. If the wake frequency is at or near the natural frequency of a given thermowell, a resonance condition may cause massive amounts of energy to be absorbed by the thermowell. This results in very high stresses and possible failures. Even if the thermowell does not fail, the sensor capsule may be subjected to severe levels of shock and vibration, resulting in erroneous readings or total sensor failure.

The ASME technique requires that the ratio of wake frequency to the natural frequency of a thermowell be less than 0.8. If the ratio is greater than 0.8, a user has two options:

1. Reducing the flow velocity or use a larger diameter thermowell; or
2. Use a stronger thermowell configuration (a different thermowell type or material, or a shorter length thermowell).

Flow-Induced Stress

Fluid flow, a function of flow velocity and density, causes force to be exerted on the thermowell. The flow-induced stress is calculated and compared with the material strength of the thermowell.

Process Pressure

The maximum static pressure that a thermowell stem can undergo is calculated.

NOTE

The thermowell analysis process is an aid in choosing thermowells for specific applications. It is based upon accepted theoretical methods and not meant to be a guarantee against thermowell failure.

Application Data Sheet

Calculations conducted per ASME/ANSI PTC 19.3 but with Strouhal number varying with Reynolds number. Please complete and fax to appropriate locations at the bottom of this form.

Company Information

Requesting Company: Phone: Fax:
 Contact Tag Number
 End Customer Date of Request:

Thermowell Information (Information for either (a), (b), (c), or (d) required)

- a) Rosemount Thermowell Part Number (example 0096D0300F04T060DQ8R01):
- b) Rosemount Sensor Model Number (example 0065C21D0135D0300T12):
- c) Customer Drawing Number
- d) Generic Thermowell Information:

Thermowell Material:

Stem Style: Straight Stepped Tapered
 Mounting Style: Threaded Welded Flanged

If flanged, specify: ANSI/ASME DIN
 Size: Class:

Thermowell Immersion Length (U):
 Thermowell Bore Diameter (D):
 Thermowell Lagging Length (T):
 Tip Diameter (A):
 Tip Thickness (t):
 Length from Tip to Support (U):
 Root Diameter (B)⁽¹⁾:
 Length of Tip Diameter (Z):

Mounting Style

Stem Style

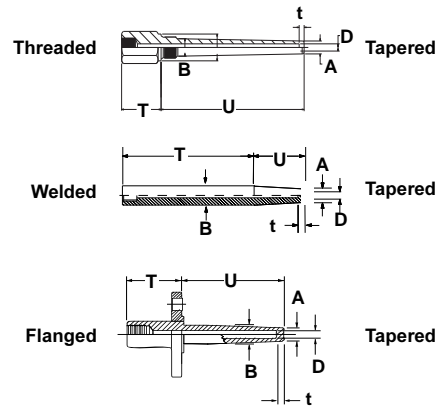

Service: <input type="checkbox"/> Liquid <input type="checkbox"/> Gas <input type="checkbox"/> Steam		Fluid Description:
Operating Fluid Flow Rate: Maximum		
Operating Fluid Flow Rate Units:		
<input type="checkbox"/> gal/s <input type="checkbox"/> gal/min <input type="checkbox"/> gal/hr <input type="checkbox"/> l/s <input type="checkbox"/> l/min <input type="checkbox"/> l/hr <input type="checkbox"/> ft/s <input type="checkbox"/> ft ³ /min <input type="checkbox"/> ft ³ /hr <input type="checkbox"/> bbl/hr <input type="checkbox"/> impgal/s <input type="checkbox"/> impgal/min <input type="checkbox"/> impgal/hr <input type="checkbox"/> m/s <input type="checkbox"/> m ³ /min <input type="checkbox"/> m ³ /hr <input type="checkbox"/> shon/hr <input type="checkbox"/> lb/hr <input type="checkbox"/> kg/s <input type="checkbox"/> kg/hr <input type="checkbox"/> other:		
Operating Max. Fluid Pressure: <input type="checkbox"/> Gauge <input type="checkbox"/> Absolute		Operating Min. Fluid Pressure: <input type="checkbox"/> Gauge <input type="checkbox"/> Absolute
Pressure Units:		Pressure Units:
Operating Fluid Temperature: <input type="checkbox"/> °F <input type="checkbox"/> °C		Viscosity: <input type="checkbox"/> kg/m•s (Pa•s) <input type="checkbox"/> Centipoise
Operating Fluid Density: <input type="checkbox"/> kg/m ³ <input type="checkbox"/> lbm/ft ³		or Specific Volume/Density: <input type="checkbox"/> at process conditions <input type="checkbox"/> at standard conditions (STP)
Process Pipe Size: Process Pipe Size:		Pipe Standoff Height: Standoff Schedule: or Standoff Internal Diameter:

For Rosemount Internal Use Only

Rosemount Order/Quotation # Line Item # Ship Set # ID #
 Customer Order/Item # Salesperson:
 Cont. Admin. Tech. Specialist:

(1) Same as A for straight thermowells.

Sensors and Accessories (Metric)

Product Data Sheet
00813-0200-2654, Rev HA
February 2008

*Rosemount and the Rosemount logotype are registered trademarks of Rosemount Inc.
Hastelloy is a registered trademark of Haynes International.
Monel and Inconel is a registered trademark of International Nickel Co. All other marks are the property of their respective owners.*

Standard Terms and Conditions of Sale can be found at www.rosemount.com/terms_of_sale

Emerson Process Management

Rosemount Inc.

8200 Market Boulevard
Chanhassen, MN 55317 USA
T (U.S.) 1-800-999-9307
T (International) (952) 906-8888
F (952) 949-7001

www.rosemount.com

Emerson Process Management

Heath Place
Bognor Regis
West Sussex PO22 9SH
England
Tel 44 (1243) 863 121
Fax 44 (1243) 867 554

Emerson Process Management Asia

Pacific Private Limited

1 Pandan Crescent
Singapore 128461
T (65) 6777 8211
F (65) 6777 0947
Enquiries@AP.emersonprocess.com

